



Kenya Power

**TENDER NO.KP1/9A.2/OT/021/ICT/19-20 FOR
SUPPLY AND INSTALLATION OF UNINTERRUPTABLE
POWER SUPPLY (UPS) FOR DISASTER RECOVERY
CENTRE, ELECTRICITY HOUSE NAIROBI**

DATE OF TENDER DOCUMENT: OCTOBER, 2019

**ALL TENDERERS ARE ADVISED TO READ CAREFULLY THIS TENDER DOCUMENT
IN ITS ENTIRETY BEFORE MAKING ANY BID**

TENDER DOCUMENT FOR SERVICES

THE KENYA POWER & LIGHTING COMPANY LIMITED
CENTRAL OFFICE, STIMA PLAZA,
KOLOBOT ROAD, PARKLANDS,
P.O. BOX 30099-00100,
NAIROBI,
KENYA.

Telephones: +254-020-3201000; 3644000 Pilot Lines

Telephones: +254 -720-600070/1-5; -733-755001/2-3 Cellular

Website: www.kplc.co.ke

Email : 1: Jmbugua@kplc.co.ke

2: Cmwogi@kplc.co.ke

3: JNdinya@kplc.co.ke

4: SMakuba@kplc.co.ke

TABLE OF CONTENTS

SECTION I - INVITATION TO TENDER 3

SECTION II - TENDER SUBMISSION CHECKLIST 4

SECTION III - INSTRUCTIONS TO TENDERERS (ITT) 7

SECTION IV - SCHEDULE OF REQUIREMENTS 26

SECTION V – PRICE SCHEDULE FOR GOODS AND SERVICES 31

SECTION VI - EVALUATION CRITERIA 32

SECTION VII – GENERAL CONDITIONS OF CONTRACT 39

SECTION VIII – SPECIAL CONDITIONS OF CONTRACT 49

SECTION IX - TENDER FORM 50

SECTION X - CONFIDENTIAL BUSINESS QUESTIONNAIRE FORM 52

SECTION XI A - TENDER SECURITY FORM – (BANK GUARANTEE) 55

SECTION XI B - TENDER SECURITY FORM (SACCO SOCIETY, DEPOSIT TAKING MICRO FINANCE INSTITUTIONS, WOMEN ENTERPRISE FUND & YOUTH ENTERPRISE FUND) 57

SECTION XI C - TENDER SECURITY – (LETTERS OF CREDIT) 59

SECTION XII - MANUFACTURER’S/ PRINCIPAL’S AUTHORIZATION FORM 61

SECTION XIII - DECLARATION FORM 62

SECTION XIV – DRAFT LETTER OF NOTIFICATION OF AWARD 63

SECTION XV – DRAFT LETTER OF NOTIFICATION OF REGRET 64

SECTION XVI - CONTRACT AGREEMENT FORM 65

SECTION XVII A - PERFORMANCE SECURITY FORM (BANK GUARANTEE) 70

SECTION XVII B - PERFORMANCE SECURITY (LC) 72

SECTION XVIII – SUBCONTRACTORS 74

SECTION XIX - PREVIOUS EXPERIENCE WITH SIMILAR WORK 75

SECTION XX - SUPPLIER EVALUATION FORM 76

SECTION XXI - PRE-BID MEETING ATTENDANCE FORM 79

SECTION XXII - THE DETAILS OF SERVICES 80

SECTION I - INVITATION TO TENDER

DATE: 22ND OCTOBER, 2019

TENDER NO.KP1/9A.2/OT/021/ICT/19-20 FOR SUPPLY AND INSTALLATION OF UNINTERRUPTABLE POWER SUPPLY (UPS) FOR DISASTER RECOVERY CENTRE, ELECTRICITY HOUSE NAIROBI

- 1.1 The Kenya Power & Lighting Company Limited hereinafter referred to KPLC invites bids from eligible tenderers for Tender No.KP1/9A.2/OT/021/ICT/19-20 for Supply and Installation of Uninterruptable Power Supply (UPS) for Disaster Recovery Centre , Electricity House Nairobi Interested eligible Tenderers may obtain further information from the General Manager- Supply Chain, The Kenya Power & Lighting Company Ltd at Stima Plaza, 3rd Floor, Kolobot Road, P.O. Box 30099 – 00100 Nairobi, Kenya.
- 1.2 **Obtaining tender documents.**
 - 1.2.1 Tender documents detailing the requirements may be obtained from the KPLC E-Procurement Portal .
 - 1.2.2 Prospective bidders may also download the tender document from KPLC’s website (www.kplc.co.ke) free of charge.
- 1.3 Submission of Tender documents
Completed Tenders are to be submitted in electronic format on the KPLC’s E-procurement portal on the due date and time published on the portal. Tenderers are required to visit the portal from time to time for revised closing dates and addendums. The Tender is to be submitted **ONLINE** on or before the submission date and time indicated on the **KPLC tendering portal**.
- 1.4 Prices
Prices quoted should be inclusive of all taxes and delivery costs to the required site (where applicable) and must be in Kenya Shillings or a freely convertible currency in Kenya and shall remain valid for one hundred and eighty (180) days from the closing date of the tender.
Please note that prices indicated on the KPLC tendering portal should be exclusive of VAT.
- 1.5 Opening of submitted Tenders
Tenders will be opened promptly thereafter in the presence of the Tenderer’s or their representatives who choose to attend in KPLC Auditorium at Stima Plaza, Kolobot Road, Parklands, Nairobi on **Tuesday 12/11/2019 at 10.30 am.**
- 1.5 Pre-bid/Site Visit meeting
There will be a pre-bid meeting to be held at KPLC’s premises, **Electricity house, Nairobi, Kenya at 10.30 a.m. on Wednesday 30 October, 2019.** Attendance for all prospective bidders is recommended.

SECTION II - TENDER SUBMISSION CHECKLIST

Tender Submission Format

Bidders are advised to clearly label their documents while uploading on the portal.

No.	Item	Tick Where Provided
1	Tender Security – Bank Guarantee or Letters of Credit (issued by Banks Licensed by the Central Bank of Kenya), Guarantee by a deposit taking Microfinance Institution, Sacco Society, the Youth Enterprise Development Fund or the Women Enterprise Fund.	
2	Declaration Form	
3	Duly completed Tender Form	
4	Certificate of Confirmation of Directors and Shareholding (C.R.12) for registered companies and if not a registered company registration of business name for those trading as a sole proprietor or a registration of partnership deed registered under the Kenyan law or equivalent certification for foreign tenderers.	
5*	Copy of PIN Certificate	
6*	Copy of Valid Tax Compliance Certificate	
7	Company or Firm’s Registration Certificate	
8	Confidential Business Questionnaire (CBQ)	
9*	Certificate of Confirmation of Directors and Shareholding (C.R. 12) or equivalent (for foreign tenderers)	
10	Type Test Certificates and their Reports and or Test Certificates and their Reports	
11	Copy of accreditation certificate for the testing laboratory as per ISO/ IEC 17025,	
12	Valid and current ISO 9001 Certificates or for locally manufactured or produced goods, valid Mark of Quality Certificate or Standardization Mark Certificates from the Kenya Bureau of Standards (KEBS).	
13	Catalogues and or Manufacturer’s drawings where applicable.	
14	Duly completed Schedule of Guaranteed Technical Particulars	
15	Principals Authorisation and warranty where applicable	
16	Names with full contact as well as physical addresses of previous customers of similar services and reference letters from at least two (2) previous customers	

17	Statement on Deviations	
18	Price Schedule(s)	
19	Schedule of requirements duly filled indicating services offered	
20	Audited Financial Statements. The audited financial statements required must be those that are reported within eighteen (18) calendar months of the date of the tender document. (For companies or firms that are registered or incorporated within the last one calendar year of the Date of the Tender Document, they should submit certified copies of bank statements covering a period of at least six months prior to the date of the tender document. The copies should be certified by the Bank issuing the statements. The certification should be original).	
20	Any other document or item required by the Tender Document. (The Tenderer shall specify such other documents or items it has submitted)	

***NOTES TO TENDERERS**

1. Valid Tax Compliance Certificate shall be one issued by the relevant tax authorities and valid for at least up to the tender closing date. All Kenyan registered Tenderers must provide a valid Tax Compliance Certificate.
2. All Kenyan registered Tenderers must provide the Personal Identification Number Certificate (PIN Certificate).
3. Foreign Tenderers must provide equivalent documents from their country of origin as regards Tax Compliance and PIN certificates OR statements certifying that the equivalent documentation is not issued in the Tenderer's country of origin. The Statement(s) that equivalent documentation is not issued by the Tenderer's country should be original and issued by the Tax authorities in the Tenderer's country of origin.

TABLE OF PARAGRAPHS ON INSTRUCTIONS TO TENDERERS

Paragraph No.	Headings	Page No.
3.1	Definitions.....	7
3.2	Eligible Tenderers	8
3.3	Joint Venture	9
3.4	Cost of Tendering.....	10
3.5	Contents of the Tender Document	10
3.6	Clarification of Documents	11
3.7	Amendment of Documents	11
3.8	Language of Tender	11
3.9	Documents Comprising the Tender.....	11
3.10	Tender Form.....	12
3.11	Tender Prices	12
3.12	Tender Currencies	13
3.13	Tenderer’s Eligibility and Qualifications	13
3.14	Conformity of Services to Tender Documents	14
3.15	Demonstration(s), Inspection(s) and Test(s)	14
3.16	Warranty	15
3.17	Tender Security	15
3.18	Validity of Tenders	16
3.19	Alternative Offers	17
3.20	Preparation and Signing of the Tender.....	17
3.21	Deadline for Submission of Tenders	17
3.22	Modification and Withdrawal of Tenders	17
3.23	Opening of Tenders.....	18
3.24	Process to be Confidential.....	18
3.25	Clarification of Tenders and Contacting KPLC	18
3.26	Preliminary Evaluation and Responsiveness.....	19
3.27	Minor Deviations, Errors or Oversights	19
3.28	Technical Evaluation and Comparison of Tenders	19
3.29	Financial Evaluation	20
3.30	Preferences	20
3.31	Debarment of a Tenderer	21
3.32	Confirmation of Qualification for Award	21
3.33	Award of Contract.....	21
3.34	Termination of Procurement Proceedings	21
3.35	Notification of Award	21
3.36	Signing of Contract	22
3.37	Performance Security	22
3.38	Corrupt or Fraudulent Practices	23

SECTION III - INSTRUCTIONS TO TENDERERS (ITT)

3.1 Definitions

In this tender, unless the context or express provision otherwise requires: -

- a) *Any reference to any Act shall include any statutory extension, amendment, modification, re-amendment or replacement of such Act and any rule, regulation or order made there-under.*
- b) *“Date of Tender Document” shall be the **start date** specified on the KPLC tendering portal.*
- c) *“Day” means calendar day and “month” means calendar month.*
- d) *“KEBS” wherever appearing means the Kenya Bureau of Standards or its successor(s) and assign(s) where the context so admits.*
- e) *“KENAS” wherever appearing means the Kenya National Accreditation Service or its successor(s) and assign(s) where the context so admits*
- f) *“PPRA” wherever appearing means The Public Procurement Regulatory Authority or its successor(s) and assign(s) where the context so admits.*
- g) *Reference to “the tender” or the “Tender Document” includes its appendices and documents mentioned hereunder and any reference to this tender or to any other document includes a reference to the other document as varied supplemented and/or replaced in any manner from time to time.*
- h) *“The Procuring Entity” means The Kenya Power and Lighting Company Limited or its successor(s) and assign(s) where the context so admits (hereinafter abbreviated as KPLC).*
- i) *“The Tenderer” means the person(s) submitting its Tender for the supply, installation and commissioning (where applicable) of the goods in response to the Invitation to Tender.*
- j) *Where there are two or more persons included in the expression the “Tenderer”, any act or default or omission by the Tenderer shall be deemed to be an act, default or omission by any one or more of such persons.*
- k) *Words importing the masculine gender only, include the feminine gender or (as the case may be) the neutral gender.*
- l) *Words importing the singular number only include the plural number and vice-versa and where there are two or more persons included in the expression the “Tenderer” the covenants, agreements and obligations expressed to be made or performed by the Tenderer shall be deemed to be made or performed by such persons jointly and severally.*
- m) *KPLC’s “authorised person” shall mean its MD & CEO who is designated by the PPAD Act 2015 to exercise such power, authority or*

discretion as is required under the tender and any contract arising therefrom, or such other KPLC staff delegated with such authority.

- n) Citizen contractors-means a person/firm wholly owned and controlled by person(s) who are citizens of Kenya.*
- o) Local contractors- a firm shall be qualified as a local contractor if it is registered in Kenya.*

3.2 Eligible Tenderers

3.2.1 A tenderer is eligible to bid for this contract only if the tenderer satisfies the following criteria—

- (a) the tenderer has the legal capacity to enter into a contract for procurement or asset disposal;
- (b) the tenderer is not insolvent, in receivership, bankrupt or in the process of being wound up;
- (c) the tenderer, if a member of a regulated profession, has satisfied all the professional requirements;
- (d) the tenderer and his or her sub-contractor, if any, is not debarred;
- (e) the tenderer has fulfilled tax obligations;
- (f) the tenderer has not been convicted of corrupt or fraudulent practices;
- and
- (g) is not guilty of any serious violation of fair employment laws and practices.

In addition, this Invitation to Tender is open to all Tenderers eligible as described in the **Appendix to Instructions to Tenderers**.

Successful Tenderers shall supply the goods in accordance with this tender and the ensuing contract.

- 3.2.2 In addition the tenderer shall be considered ineligible to bid, where in case of a corporation, private company, partnership or other body, the tenderer, their spouse, child or sub-contractor has substantial or controlling interest and is found to be in contravention of the provisions of section 3.2.1 above.
- 3.2.3 The Procuring Entity's employees, committee members, board members, and their relative (spouse and children) are not eligible to participate in this tender.
- 3.2.4 Despite the provisions of section 3.2.3 and 3.2.4, a tenderer having a substantial or controlling interest shall be eligible to bid where—
 - (a) such tenderer has declared any conflict of interest; and
 - (b) performance and price competition for that good, work or service is not available or can only be sourced from that tenderer.

- 3.2.5 For the purposes of this paragraph, any relative i.e. spouse(s) and child(ren) of any person mentioned in sub-paragraph 3.3.1 is also ineligible to participate in the tender.
- 3.2.6 Tenderers shall provide the qualification information statement that the Tenderer (including subcontractors) is not associated, or have been associated in the past, directly or indirectly, with a firm or any of its affiliates which have been engaged by KPLC to provide consulting services for the preparation of the design, specifications, and other documents to be used for the procurement of the goods under this Invitation to Tender.
- 3.2.7 Tenderers shall not be under declarations as prescribed at Section XIII.
- 3.2.8 Tenderers who are not under these declarations shall complete the Declaration Form strictly in the form and content as prescribed at Section XIII.
- 3.2.9 Those that are under the Declaration as prescribed at Section XIII whether currently or in the past shall not complete the Form. They will submit a suitable Form giving details, the nature and present status of their circumstances.
- 3.2.10 Those that are under the Declaration as prescribed at Section XIII whether currently or in the past shall not complete the Form. They will submit a suitable Form giving details, the nature and present status of their circumstances.

3.3 Joint Venture

- 3.3.1 Tenders submitted by a joint venture of two or more firms, as partners shall comply with the following requirements: -
- a) the Tender Form and in case of a successful tender, the Contract Agreement Form, shall be signed so as to be legally binding on all partners of the joint venture.
 - b) one of the partners shall be nominated as being lead contractor, and this authorization shall be evidenced by submitting a Power of Attorney signed by legally authorized signatories of all the partners.
 - c) The Power of Attorney which shall accompany the tender, shall be granted by the authorized signatories of all the partners as follows:-
 - (i.) for local bidders, before a Commissioner of Oaths or a Notary Public or Magistrate of the Kenyan Judiciary.
 - (ii.) for a foreign bidder, before a Notary Public, or the equivalent of a Notary Public, and in this regard the bidder shall provide satisfactory proof of such equivalence.
 - d) the lead contractor shall be authorized to incur liability and receive instructions for and on behalf of any and all the partners of the joint venture and the entire execution of the contract including payment shall be done exclusively with the lead contractor.
- 3.3.2 All partners of the joint venture shall be liable jointly and severally for the execution of the contract in accordance with the contract terms, and a relevant

statement to this effect shall be included in the authorization mentioned in paragraph 3.3.1 (b) above as well as in the Form of Tender and the Contract Agreement Form (in case of the accepted tender).

3.3.3 A copy of the agreement entered into by the joint venture partners shall be submitted with the tender.

3.4 Cost of Tendering

3.4.1 The Tenderer shall bear all costs associated with the preparation and submission of its Tender, and KPLC will in no case be responsible or liable for those costs, regardless of the conduct or outcome of the tendering process.

3.5 Contents of the Tender Document

3.5.1 The Tender Document comprises the documents listed below and Addendum (where applicable) issued in accordance with paragraph 3.7 of these Instructions to Tenderers: -

- a) *Invitation to Tender*
- b) *Tender Submission Checklist*
- c) *Instructions to Tenderers*
- d) *Appendix to Instructions to Tenderers*
- e) *Schedule of Requirements*
- f) *Project Implementation Schedule*
- g) *Price Schedule for Services*
- h) *Evaluation Criteria*
- i) *General Conditions of Contract*
- j) *Special Conditions of Contract*
- k) *Tender Form*
- l) *Confidential Business Questionnaire Form*
- m) *Tender Security Form*
- n) *Manufacturer's Authorization Form*
- o) *Manufacturer's Warranty*
- p) *Declaration Form*
- q) *Contract Form*
- r) *Performance Security Form*
- s) *Details of Service*
 - (i.) *General Requirements*
 - (ii.) *Specific Details of Services*

3.5.2 The Tenderer is expected to examine all instructions, forms, provisions, terms and specifications in the Tender Document. Failure to furnish all information required by the

Tender Document or to submit a tender not substantially responsive to the Tender Document in every respect will be at the Tenderer's risk and may result in the rejection of its Tender.

- 3.5.3 All recipients of the documents for the proposed Contract for the purpose of submitting a tender (*whether they submit a tender or not*) shall treat the details of the documents as "Private and Confidential".

3.6 Clarification of Documents

A prospective Tenderer requiring any clarification of the Tender Document may notify the General Manager Supply Chain in writing and ensure receipt is acknowledged at KPLC's Physical address indicated on the Tender Document. KPLC will respond in writing to any request for clarification of the Tender documents, which it receives not later than seven (7) days prior to the deadline for the submission of Tenders, prescribed by KPLC. Written copies of KPLC's response (*including an explanation of the query but without identifying the source of inquiry*) will be published and accessible to all prospective Tenderers on the KPLC's tendering portal.

3.7 Amendment of Documents

- 3.7.1 At any time prior to the deadline for submission of Tenders, KPLC, for any reason, whether at its own initiative or in response to a clarification requested by a prospective Tenderer, may modify the tender documents by amendment.
- 3.7.2 All prospective Tenderers that have registered in the portal for the Tender will be notified of the amendment(s) (*hereinafter referred to or otherwise known as addendum*) in writing and will be binding on them.
- 3.7.3 In order to allow prospective Tenderers reasonable time in which to take the amendment into account in preparing their Tenders, KPLC, at its discretion, may extend the deadline for the submission of Tenders.

3.8 Language of Tender

The Tender prepared by the Tenderer, as well as all correspondence and documents relating to the tender, exchanged between the Tenderer and KPLC, shall be written in English language. Any printed literature furnished by the Tenderer written in any other language shall be accompanied by an accurate English translation of the relevant passages, in which case, for purposes of interpretation of the Tender, the English translation shall govern. The English translation shall be on the Tenderer's letterhead and shall be signed by the duly authorized signatory signing the Tender and stamped with the Tenderer's stamp.

3.9 Documents Comprising the Tender

The Tender prepared and submitted by the Tenderers shall include but not be limited to all the following components: -

- a) *Declaration Form, Tender Form and a Price Schedule completed in compliance with paragraphs 3.2, 3.10, 3.11 and 3.12.*
- b) *Documentary evidence established in accordance with paragraph 3.13 that the Tenderer is eligible to tender and is qualified to perform the contract if its tender is accepted.*
- c) *Documentary evidence established in accordance with paragraph 3.14 that the services and any ancillary thereto to be provided by the Tenderer conform to the tender documents, and,*
- d) *Tender Security furnished in accordance with paragraph 3.17*
- e) *A detailed list of previous customers as prescribed for similar services on tender and their contact addresses shall be submitted with the Tender for the purpose of reference, or for evaluation where the Details of Service so dictate.*
- f) *And all other documents indicated in Section II (Tender Submission Checklist)*

3.10 Tender Form

The Tenderer shall complete and sign the Tender Form and all other documents furnished in the Tender Document, indicating the services to be performed, a brief description of the services, quantity (where applicable), and prices amongst other information required.

3.11 Tender Prices

- 3.11.1 The Tenderer shall indicate on the appropriate Price Schedule, the unit prices (where applicable) and total tender price of the services it proposes to provide under the contract.
- 3.11.2 Prices indicated on the Price Schedule shall be of all costs for the services including insurances, duties, Value Added Tax (V.A.T) and other taxes payable. No other basis shall be accepted for evaluation, award or otherwise.
- 3.11.3 Section 20 of the Insurance Act Cap 487 requires all imports to the country to be insured with a local insurance company. It is now mandatory for all marine cargo imports to adhere to this requirement.
- 3.11.4 Tender prices to be submitted (quoted) by the Tenderer shall remain fixed for the contract duration.
- 3.11.5 A price that is derived by a disclosed incorporation or usage of an international accepted standard formula shall be acceptable within the meaning of this paragraph.

3.12 Tender Currencies

- 3.12.1 For services that the Tenderer will provide from within or outside Kenya, the prices shall be quoted in Kenya Shillings, or in another freely convertible currency in Kenya. The currency quoted must be indicated clearly on the Price Schedule of Services.
- 3.12.2 The exchange rate to be used for currency conversion shall be the Central Bank of Kenya selling rate prevailing on the Tender closing date. *(Please visit the Central Bank of Kenya website).*

3.13 Tenderer's Eligibility and Qualifications

- 3.13.1 Pursuant to paragraph 3.2, the Tenderer shall furnish, as part of its Tender, documents establishing the Tenderer's eligibility to tender and its qualifications to perform the contract if its Tender is accepted.
- 3.13.2 The documentary evidence of the Tenderer's qualifications to perform the contract if its Tender is accepted shall be established to KPLC's satisfaction –
- a) *that, in the case of a Tenderer offering to perform the services under the contract which the Tenderer is not the Principal, the Tenderer has been duly authorized by the Manufacturer, Principal or Producer to provide the services. The authorization shall strictly be in the form and content as prescribed in the Manufacturer's or Principal's Authorization Form in the Tender Document*
 - b) *that the Tenderer has the financial capability necessary to perform the contract. The Tenderer shall be required to provide the documents as specified in the Appendix to Instructions to Tenderers including a current Tax Compliance Certificate issued by the relevant tax authorities.*
 - c) *that the Tenderer has the technical and production capability necessary to perform the contract.*
 - d) *that, in the case of a Tenderer not doing business within Kenya, the Tenderer is or will be (if awarded the contract) represented by an agent in Kenya equipped, and able to carry out the Tenderer's maintenance, repair, spare parts and stocking obligations prescribed in the Conditions of Contract and or in the Details of Service.*
 - e) *that the Tenderer is duly registered and is a current member of a recognized body or institution accredited and or pertaining to that service.*
- 3.13.3 The Tenderer will furnish KPLC with a copy of the accreditation or recognition certificate as applicable. KPLC reserves the right to subject the certificate to authentication.
- 3.13.4 Tenderers with a record of unsatisfactory or default in performance obligations in any contract shall not be considered for evaluation or award. For the avoidance of

doubt, this shall include any Tenderer with unresolved case(s) in its obligations for more than two (2) months in any contract.

3.14 Conformity of Services to Tender Documents

- 3.14.1 The Tenderer shall furnish, as part of its tender, documents establishing the conformity to the Tender Document of all services that the Tenderer proposes to perform under the contract.
- 3.14.2 The documentary evidence of conformity of the services to the Tender Document may be in the form of literature, drawings, and data, and shall (where applicable) consist of: -
- a) *a detailed description of the essential technical and performance characteristics of the services whether in catalogues, drawings or otherwise,*
 - b) *a list giving full particulars, including available source and current prices of spare parts, special tools and other incidental apparatus necessary for the proper and continuing performance of the services for a minimum period of two (2) years following commencement of the provision of the services to KPLC, and,*
 - c) *duly completed Statement of Compliance to KPLC's Details of Service demonstrating substantial responsiveness of the service to those Details or, a statement of deviations and exceptions to the provisions of the Details of Service.*
- 3.14.3 For purposes of the documentary and other evidence to be furnished pursuant to subparagraphs 3.14.1, 3.14.2 and paragraph 3.15, the Tenderer shall note that standards for workmanship, material, and equipment, designated by KPLC in its Details of Service are intended to be descriptive only and not restrictive. The Tenderer may adopt higher standards in its Tender, provided that it demonstrates to KPLC's satisfaction that the substitutions ensure substantial equivalence to those designated in the Details of Service.

3.15 Demonstration(s), Inspection(s) and Test(s)

- 3.15.1 Where required in the tender, all Tenderers shall demonstrate ability of performance of the required service in conformity with the Details of Services.
- 3.15.2 KPLC or its representative(s) shall have the right to inspect/ test the Tenderer's capacity, equipment, premises, and to confirm their conformity to the tender requirements. This shall include the quality management system. KPLC's representative(s) retained for these purposes shall provide appropriate identification at the time of such inspection/ test.
- 3.15.3 KPLC shall meet its own costs of the inspection/ test. Where conducted on the premises of the Tenderer(s), all reasonable facilities and assistance, including
- access to drawings and production data, shall be furnished to the inspectors at no charge to KPLC.
- 3.15.4 Demonstration, Inspection/ Test Report(s) shall be completed upon conclusion of the inspection/ tests. This Report will be considered at time of evaluation and or award.

3.16 Warranty

- 3.16.1 Where required in the Tender, all Tenderers must also provide a Warranty that services to be rendered in the Tenderer's bid have no defect arising from manufacture, materials or workmanship or from any act or omission of the Tenderer that may develop under normal use or application of the services under the conditions obtaining in Kenya.
- 3.16.2 This warranty will remain valid for the period indicated in the special conditions of contract after the services, or any portion thereof as the case may be, have been rendered.

3.17 Tender Security

- 3.17.1 The Tenderer shall furnish, as part of its Tender, a tender security for the amount specified in the Appendix to Instructions to Tenderers. The Original Tender Security, in a clearly labelled envelop, shall be deposited in the Tender Security Box on **3rd Floor, Procurement entrance** on or before the opening date and time and receipt acknowledged by KPLC evidenced by a stamped copy.
- 3.17.2 The tender security shall be either one or a combination of the following: -
- a) an original Bank Guarantee that is strictly in the form and content as prescribed in the Tender Security Form (Bank Guarantee) in the Tender Document.
 - b) For Local bidders, Standby Letters of Credit (LC). All costs, expenses and charges levied by all banks party to the LC shall be prepaid/borne by the Tenderer. The LC must contain all the mandatory conditions of payment to KPLC as prescribed in the Tender Security (Letters of Credit) provided in the Tender Document.
 - c) For Foreign bidders, Standby Letters of Credit (LC) confirmed by a bank in Kenya. All costs, expenses and charges levied by all banks party to the LC including confirmation charges shall be prepaid/borne by the Tenderer. The LC must contain all the mandatory conditions of payment to KPLC as prescribed in the Tender Security (Letters of Credit) provided in the Tender Document.
 - d) An original Guarantee by a deposit taking Microfinance Institution, Sacco Society, Youth Enterprise Development Fund or the Women Enterprise Fund, that is strictly in the form and content as prescribed in the Tender Security Form
- 3.17.3 The tender security is required to protect KPLC against the risk of the Tenderer's conduct which would warrant the security's forfeiture pursuant to paragraph 3.17.10.
- 3.17.4 The Tender Security shall be denominated in Kenya Shillings or in another freely convertible currency in Kenya. A Tender Security in form of a Bank Guarantee or a Standby Letter of Credit issued on behalf of local bidders, should be from a commercial bank licensed by the Central Bank of Kenya. A Tender Security in form of a Standby Letter of Credit issued on behalf of foreign bidders by foreign banks, should be confirmed by a commercial bank licensed by the Central Bank of Kenya.

- 3.17.5 The Tender Security shall be valid for thirty (30) days beyond the validity of the tender.
- 3.17.6 KPLC shall seek authentication of the Tender Security from the issuing bank. It is the responsibility of the Tenderer to sensitize its issuing bank on the need to respond directly and expeditiously to queries from KPLC. The period for response shall not exceed five (5) days from the date of KPLC's query. Should there be no conclusive response by the bank within this period, such Tenderer's Tender Security may be deemed as invalid and the bid rejected.
- 3.17.7 Any Tender not secured in accordance with this paragraph will be rejected by KPLC as non-responsive, pursuant to paragraph 3.26.
- 3.17.8 The unsuccessful Tenderer's Tender Security will be released as promptly as possible, in any of the following circumstances: -
- a) *the procurement proceedings are terminated*
 - b) *KPLC determines that none of the submitted Tenders is responsive*
 - c) *a contract for the procurement is entered into.*
- 3.17.9 The successful Tenderer's Tender Security will be released upon the successful Tenderer's signing the contract, pursuant to paragraph 3.39 and furnishing an authentic Performance Security, pursuant to paragraph 3.40.
- 3.17.10 The Tender Security shall be forfeited –
- a) *if the Tenderer withdraws its Tender after the deadline for submitting Tenders but before the expiry of the period during which the Tenders must remain valid*
 - b) *if the Tenderer fails to enter into a written contract in accordance with paragraph 3.39*
 - c) *if the successful Tenderer fails to furnish the performance security in accordance with paragraph 3.40*
 - d) *if the Tenderer fails to extend the validity of the tender security where KPLC has extended the tender validity period in accordance with paragraph 3.18.*

3.18 Validity of Tenders

- 3.18.1 Tenders shall remain valid for one hundred and eighty (180) days after the date of tender opening as specified in the Invitation to Tender or as otherwise may be prescribed by KPLC, pursuant to paragraph 3.23. A Tender that is valid for a shorter period shall be rejected by KPLC as non-responsive.
- 3.18.2 In exceptional circumstances, KPLC may extend the Tender validity period. The extension shall be made in writing. The tender security provided under paragraph 3.17 shall also be extended. A Tenderer shall not be required nor permitted to modify its tender during the extended period

3.19 Alternative Offers

Only main offers shall be considered, as alternative offers are not acceptable.

3.20 Preparation and Signing of the Tender

- 3.20.1 The Tender shall be typed or written in indelible ink. It shall be signed by the Tenderer or a person or persons duly authorized to bind the Tenderer to the contract.
- 3.20.2 The authorization shall be indicated by a written Power of Attorney granted by the Tenderer to the authorized person before any of the following persons:-
- a) *For local Tenderers, a Commissioner of Oaths or a Notary Public or a Magistrate of the Kenyan Judiciary.*
 - b) *For foreign Tenderers, a Notary Public in the country of the Tenderer.*
- In either case above, the Power of Attorney shall accompany the Tender.
- 3.20.3 All pages of the Tender, including un-amended printed literature, shall be initialled by the person or persons signing the Tender and serially numbered.
- 3.20.4 The Tender shall have no interlineations, erasures, or overwriting except as necessary to correct errors made by the Tenderer, in which case such corrections shall be initialled by the person or persons signing the Tender.
- 3.20.5 KPLC will assume no responsibility whatsoever for the Tenderer's failure to comply with or observe the entire contents of this paragraph 3.20.
- 3.20.6 Any Tender not prepared and signed in accordance with this paragraph may be rejected by KPLC as non-responsive, pursuant to paragraph 3.20

3.21 Deadline for Submission of Tenders

- 3.21.1 Tenders must be received by KPLC by the date and time specified in KPLC's tendering portal in PDF form.
- 3.21.2 KPLC may, at its discretion, extend this deadline for submission of Tenders by amending the tender documents in accordance with paragraph 3.7, in which case all rights and obligations of KPLC and the Tenderer previously subject to the initial deadline, will therefore be subject to the deadline as extended.

3.22 Modification and Withdrawal of Tenders

- 3.22.1 The Tenderer may modify or withdraw its Tender after it has submitted, provided that the modification, including substitution or withdrawal of the Tender is received by KPLC prior to the deadline prescribed for submission of tenders.
- 3.22.2 No Tender may be modified after the deadline for submission of Tenders.
- 3.22.3 No Tender may be withdrawn in the interval between the deadline for submission of tenders and the expiration of the period during which the Tender must remain valid except where KPLC extends the initial validity period. Any withdrawal of a Tender during this interval

shall result in forfeiture of the Tenderer's Tender Security except where KPLC extends the initial validity period.

3.23 Opening of Tenders

- 3.23.1 KPLC shall open all Tenders promptly at the date and time specified in the KPLC tendering portal and at the location specified in the Invitation to Tender or as may otherwise be indicated.
- 3.23.2 The Tenderer's names, tender modifications or withdrawals, the presence or absence of requisite Tender Security and such other details as KPLC, at its discretion, may consider appropriate, will be announced at the opening.
- 3.23.3 At the Tender opening, tender prices, discounts, and such other details as KPLC, at its discretion, may consider appropriate will be read out.
- 3.23.4 The Tenderers or their representatives may attend the opening and those present shall sign a register evidencing their attendance.

3.24 Process to be Confidential

- 3.24.1 After the opening of tenders, information relating to the examination, clarification, evaluation and comparisons of tenders and recommendations arising there-from shall not be disclosed to a Tenderer or other person(s) not officially concerned with such process until conclusion of that process.
- 3.24.2 Conclusion of that process shall be deemed to have occurred, at the latest, by the date and time KPLC notifies the successful bidder(s). In any event, official disclosure by KPLC of any information upon conclusion of that process may only be to the unsuccessful bidders and may contain only the information permissible by law in summary form.
- 3.24.3 Any effort by a Tenderer to influence KPLC or any of its staff members in the process of examination, evaluation and comparison of tenders and information or decisions concerning the Tender may result in the disqualification of the Tenderer.

3.25 Clarification of Tenders and Contacting KPLC

- 3.25.1 To assist in the examination, evaluation and comparison of Tenders KPLC may, at its discretion, ask the Tenderer for a clarification of its Tender. The request for clarification and the response shall be in writing, and no change in the prices or substance of the Tender shall be sought, offered, or permitted.
- 3.25.2 The Tenderer is required to provide timely clarification or substantiation of the information that is essential for effective evaluation of its qualifications. It is the responsibility of the Tenderer to provide in writing the clarification or substantiation which should reach KPLC within five (5) days from the date of KPLC's query. Such writing may include by electronic mail, facsimile or postal mail. Should there be no conclusive response within this period, it shall result in the Tenderer's disqualification.

- 3.25.3 Save as is provided in this paragraph and paragraph 3.22 above, no Tenderer shall contact KPLC on any matter related to its Tender, from the time of the tender opening to the time the successful Tenderer is announced..
- 3.25.4 Any effort by a Tenderer to influence KPLC in its decisions on tender evaluation, tender comparison, tender recommendation(s) or signing of Agreement may result in the disqualification of the Tenderer.

3.26 Preliminary Evaluation and Responsiveness

- 3.26.1 Prior to the detailed Technical and Financial evaluation, KPLC will determine the substantial responsiveness of each Tender. For purposes of this tender, a substantially responsive Tender is one that conforms to the requirements of Preliminary Evaluation. KPLC's determination of a Tender's responsiveness is to be based on the contents of the Tender itself without recourse to extrinsic evidence.
- 3.26.2 KPLC will examine the Tenders to determine whether they conform to the Preliminary Evaluation Criteria set out in Section VI Evaluation Criteria.
- 3.26.3 Notwithstanding the contents of the foregoing sub-paragraphs, if a Tender is not substantially responsive, it will be rejected at the earliest stage of evaluation by KPLC and cannot subsequently be made responsive by the Tenderer by correction of any non-conformity.

3.27 Minor Deviations, Errors or Oversights

- 3.27.1 KPLC may waive any minor deviation in a Tender that does not materially depart from the requirements of the goods and or services set out in the Tender Document.
- 3.27.2 Such minor deviation -
 - 3.27.2.1 shall be quantified to the extent possible,*
 - 3.27.2.2 shall be taken into account in the evaluation process, and,*
 - 3.27.2.3 shall be applied uniformly and consistently to all qualified Tenders duly received by KPLC.*
- 3.27.3 KPLC may waive errors and oversights that can be corrected without affecting the substance of the Tender.

3.28 Technical Evaluation and Comparison of Tenders

- 3.28.1 KPLC will further evaluate and compare the Tenders that have been determined to be substantially responsive, in compliance to the Details of Services set out in the Tender Document and as per the prescribed Evaluation Criteria.
- 3.28.2 The Operational Plan is a critical aspect of the Tender. KPLC requires that the Services shall be performed at the time specified in the Schedule of Requirements. KPLC's evaluation of a tender will also take into account the Operational Plan proposed in the Tender. Tenderers

offering to perform longer than KPLC's required delivery time will be treated as non-responsive and rejected.

3.29 Financial Evaluation

- 3.29.1 The financial evaluation and comparison shall be as set out in the Summary of Evaluation Process. The comparison shall be
- a) of the price including all costs as well as duties and taxes payable on all the materials to be used in the provision of the Services.
 - b) deviations in Payment Schedule from that specified in the Special Conditions of Contract
- 3.29.2 Where other currencies are used, KPLC will convert those currencies to the same currency using the selling exchange rate ruling on the date of tender closing provided by the Central Bank of Kenya.

3.30 Preferences

- 3.30.1 Subject to availability and realization of the applicable international or local standards, only such manufactured articles, materials or supplies wholly mined and produced in Kenya shall be subject to preferential procurement.
- 3.30.2 Despite the above provisions, preference shall be given to —
- (a) manufactured articles, materials and supplies partially mined or produced in Kenya or where applicable have been assembled in Kenya; or
 - (b) firms where Kenyans are shareholders.
- 3.30.3 The threshold for the provision under 3.30.2 (b) shall be above fifty-one percent of Kenyan shareholders.
- 3.30.1 In the evaluation of tenders, exclusive preference shall firstly be given to citizen contractors where the amount of the tender as evaluated is below Ksh. 500 Million in respect of works, goods and services.
- 3.30.2 Where a person is entitled to more than one preference scheme, the scheme with the highest advantage to the person shall be applied.
- 3.30.3 For purposes of this paragraph the Tenderer shall submit with its Tender, a valid copy of certificate of Confirmation of Directorships and Shareholding issued **and signed** by either the Registrar of Companies or Registrar of Business Names. This certificate must not be more than three (3) months old from the Date of the Tender Document. Kenya Power reserves the right to subject the certificate to authentication.

3.31 Debarment of a Tenderer

A Tenderer who gives false information in the Tender about its qualification or who refuses to enter into a contract after notification of contract award shall be considered for debarment from participating in future public procurement.

3.32 Confirmation of Qualification for Award

- 3.32.1 KPLC may confirm to its satisfaction whether the Tenderer that is selected as having submitted the best evaluated responsive tender is qualified to perform the contract satisfactorily.
- 3.32.2 The confirmation will take into account the Tenderer's financial, technical, and performance capabilities. It will be based upon an examination of the documentary evidence of the Tenderer's qualifications submitted by the Tenderer, pursuant to paragraph 3.13 as well as confirmation of such other information as KPLC deems necessary and appropriate. This may include factory, office and other facilities inspection and audits.
- 3.32.3 An affirmative confirmation will be a prerequisite for award of the contract to the Tenderer. A negative confirmation will result in rejection of the Tenderer's Tender, in which event KPLC will proceed to the next best evaluated responsive tender to make a similar confirmation of that Tenderer's capabilities to perform satisfactorily.

3.33 Award of Contract

- 3.33.1 KPLC will award the contract to the successful Tenderer whose Tender has been determined to be substantially responsive, compliant with the evaluation criteria and has been determined to be the best evaluated tender, and further, where deemed necessary, that the Tenderer is confirmed to be qualified to perform the contract satisfactorily.
- 3.33.2 Award will be done as indicated in the Appendix to Instructions to Tenderers.

3.34 Termination of Procurement Proceedings

- 3.34.1 KPLC may at any time terminate procurement proceedings before contract award and shall not be liable to any person for the termination.
- 3.34.2 KPLC shall give prompt notice of the termination to the Tenderers, and, on request from any Tenderer, give its reasons for termination within fourteen (14) days of such request.

3.35 Notification of Award

- 3.35.1 Prior to the expiration of the period of tender validity, KPLC shall notify the successful Tenderer in writing that its Tender has been accepted.
- 3.35.2 The notification of award shall not constitute the formation of the contract until one is finally signed by both parties.
- 3.35.3 Simultaneously, and without prejudice to the contents of paragraph 3.25, on issuance of Notification of Award to the successful Tenderer, KPLC shall notify each unsuccessful Tenderer.
- 3.38.4 A notification of the tender outcome does not reduce the validity period for any tender security whether the Tenderer is successful or not, except where such tender security is officially released to the Bank and/or the Tenderer and such Bank discharged of all its obligations by KPLC prior to the expiry of its stated validity period.

3.36 Signing of Contract

- 3.36.1 At the same time as KPLC notifies the successful Tenderer that its Tender has been accepted, KPLC will send the Tenderer the Contract Agreement provided in the Tender Document together with any other necessary documents incorporating all agreements between the Parties.
- 3.36.2 Within fourteen (14) days of the date of notification of award, the successful Tenderer shall only sign the Contract Form and all the documents specified in that Form and return them to KPLC within that period of fourteen (14) days.
- 3.36.3 KPLC shall sign and date the Contract in the period between not earlier than fourteen (14) days from the date of notification of contract award. Further, KPLC shall not sign the contract until and unless the authentic performance security is received in accordance with paragraph 3.36.
- 3.36.4 Failure of the successful Tenderer to sign the Contract, the award shall be annulled and its tender security forfeited in which event KPLC shall notify the next best evaluated Tenderer that its Tender has been accepted.
- 3.36.5 Paragraph 3.33 together with the provisions of this paragraph 3.35 will apply with necessary modifications with respect to the Tenderer notified under sub-paragraph 3.35.3.

3.37 Performance Security

- 3.37.1 Within fourteen (14) days of the date of notification of award from KPLC, the successful Tenderer shall furnish KPLC with a Performance Security which shall be either one or a combination of the following:
 - a) an original Bank Guarantee that is strictly in the form and content as prescribed in the Performance Security Form (Bank Guarantee) in the Tender Document.
 - b) For Local bidders, Standby Letters of Credit (LC). All costs, expenses and charges levied by all banks party to the LC shall be prepaid/borne by the Tenderer. The LC must contain all the mandatory conditions of payment to KPLC as prescribed in the Tender Security (Letters of Credit) provided in the Tender Document.
 - c) For Foreign bidders, Standby Letters of Credit (LC) confirmed by a bank in Kenya. All costs, expenses and charges levied by all banks party to the LC including confirmation charges shall be prepaid/borne by the Tenderer. The LC must contain all the mandatory conditions of payment to KPLC as prescribed in the Tender Security (Letters of Credit) provided in the Tender Document.
- 3.37.2 The Performance Security shall be issued by a commercial bank licensed by the Central Bank of Kenya. The bank must be located in Kenya.
- 3.37.3 The Performance Security shall be the sum of ten percent (10%) of the contract value. It shall be in the currency of the contract price.

3. 37.4 KPLC shall seek authentication of the Performance Security from the issuing bank. It is the responsibility of the successful Tenderer to sensitize its issuing bank on the need to respond directly and expeditiously to queries from KPLC. The period for response shall not exceed three (3) days from the date of KPLC's query. Should there be no conclusive response by the Bank within this period, such successful Tenderer's Performance Security may be deemed as invalid.
3. 37.5 Failure of the successful Tenderer to furnish an authentic Performance Security, the award shall be annulled and the Tender Security forfeited, in which event KPLC may notify the next best evaluated Tenderer that its Tender has been accepted.
3. 37.6 Paragraph 3.35, 3.36 together with the provisions of this paragraph 3. 37 will apply with necessary modifications, and as far as circumstances permit, with respect to the Tenderer notified under sub-paragraph 3.37.5.

3.38 Corrupt or Fraudulent Practices

- 3.38.1 KPLC requires that Tenderers observe the highest standard of ethics during the procurement process and execution of contracts. When used in the present Regulations, the following terms are defined as follows: -
- a) *“Corrupt practice” means the offering, giving, receiving or soliciting of any thing of value to influence the action of public official in the procurement process or in contract execution;*
 - b) *“Fraudulent practice” means a misrepresentation of facts in order to influence a procurement process or the execution of a contract to the detriment of KPLC, and includes collusive practice among Tenderers (prior to or after Tender submission) designed to establish tender prices at artificial non-competitive levels and to deprive KPLC of the benefits of free and open competition.*
3. 38.2 KPLC will nullify its notification of award if it determines that the Tenderer recommended has engaged in corrupt or fraudulent practices in competing for the contract in question.
3. 38.3 Further, a Tenderer who is found to have indulged in corrupt or fraudulent practices risks being debarred from participating in public procurement in Kenya.

APPENDIX TO INSTRUCTIONS TO TENDERERS

The following information regarding the particulars of the tender shall complement and or amend the provisions of the Instructions to Tenderers *hereinafter abbreviated as ITT*. Wherever there is a conflict between the provisions of the ITT and the Appendix, the provisions of the Appendix herein shall prevail over those of the ITT.

No.	ITT Reference Clause	Particulars of Appendix
1	3.2.1 Eligible Tenderers	<i>Eligible bidders</i>
2	3.3.1 Origin of Eligible goods	<i>Any country is eligible</i>
3	3.6 Time for Completion of Works	<i>12 months</i>
4	3.10.3 Site Visit and Pre-Bid Meeting	<i>Pre-bid meeting and site visit shall be held on Wednesday 30/10/2019 at 10.30am at Electricity House Nairobi</i>
5	3.10.6 Attendance of pre-bid meeting or site visit	<i>a) the pre-bid meeting is mandatory b) the site visits are mandatory</i>
6	3.10 Documents Comprising the Tender – List of Previous Customers	<i>The Tenderer shall submit at least four (4) names with full contact as well as physical addresses of previous customers of similar services and letters from the previous customers confirming completion of the contracts on schedule.</i>
7	3.13 Tender Currency	<i>For avoidance of doubt, the currency of the tender must be in Kenya Shillings for local bidders (for foreign bidders the convertible currency at the tender opening exchange rate)</i>
8	3.14.2 (a) Manufacturer's / Principal's Authorization	<i>A form of the minimum standard requirements is attached in the detailed technical requirements</i>
9	3.14.2 (b) Documentary evidence of financial capability	<i>The audited financial statements required must be those that are reported within eighteen (18) calendar months of the date of the tender document.</i>
10	3.14.2 (c) and (d) Documents of evidence of eligibility	<i>As indicated in 3.14.4 and 3.14.5</i>
11	3.14.2 (e) Tenderer's membership of a recognized or accredited institution.	<i>Provide all Membership and Accreditation</i>
12	3.15.2 (a) Catalogues,	<i>All technical documents and specifications</i>

	Brochures, Manufacturer's/ Principal's Drawings	<i>pertaining to the product MUST be provided</i>
13	3.17.2 Warranty	<i>Warranty of one (1) year or manufacturer's guarantee (whichever is longer).</i>
14	3.18.1 Tender Security	<i>Ksh 300,000.00. However, the original tender security shall be dropped in the tender box situated at third floor Stima Plaza</i>
15	3.21 Number of sets of and Tender Format	<i>There will be only one document submitted on the e-document portal.</i>
16	3.22 Preparation and signing of the tender	<i>There will be only one document submitted on the e-procurement portal. Bidders shall ensure they upload all the required documents into the portal.</i>
17	3.23 Sealing and Outer Marking of Tenders.	<i>For the purposes of this tender, this is not applicable as the tender is being submitted electronically. However, the original tender security in a clearly labelled envelope shall be deposited in the tender security box on 3rd floor supply chain reception on or before the opening date</i>
18	3.25 Opening of Tenders	<i>The tender shall be opened electrically at Stima Plaza auditorium on 12.11.2019 at 10:30 a.m. and bidders are encouraged to participate.</i>
19	3.36.2 Mode of Award of Contract	<i>The bid with the lowest evaluated bid price</i>
20	3.40 Performance Security	<i>Performance bond shall be 10 % of the Total Contract value.</i>

SECTION IV - SCHEDULE OF REQUIREMENTS

TENDER NO.KP1/9A.2/OT/021/ICT/19-20 FOR SUPPLY AND INSTALLATION OF UNINTERRUPTABLE POWER SUPPLY (UPS) FOR DISASTER RECOVERY CENTRE, ELECTRICITY HOUSE NAIROBI

4.1 Scope of Work

KPLC is intending to procure Supply, Delivery, Installation and Testing of 2No. x 250KW UPS for its Disaster Recovery Centre in Electricity House Nairobi.

The Contractor shall carry out all the necessary works for successful installation of the 2No. x 250KW UPSs as described and set out in this section of the Technical Specification.

The UPS system consists modules. Each module contains all the hardware and software required for full system operation. They share no common components. Each UPS module has its own independent static bypass, rectifier, inverter, logic control, control panel, battery charger and batteries. With all the critical components duplicated and distributed between individual units, potential single points of failure are eliminated.

The scope of work also includes the inter connection of neutral to the copper plate earthing by runs of appropriate copper strip. The scope also includes copper cabling between UPS, battery bank & also between input source of power supply and output switch.

4.2 Guarantee Specifications

Bidders must provide substantive responses for all features irrespective of any attached technical documents.

S/NO	FEATURE	MINIMUM SPECIFICATIONS	BIDDER'S RESPONSE
	General Specifications		<i>(Indicate page numbers on Brochures attached)</i>
1.	Modular UPS System (Decentralised Parallel Architecture)	The UPS system shall consist of an IGBT power factor-corrected rectifier, DC-DC converter and three-phase, bypass static transfer switch, bypass synchronizing circuitry, protective devices and accessories as specified. The specified system shall also include a battery disconnect breaker and battery system.	
2.	UPS type : Modular (Decentralised Parallel Architecture)		

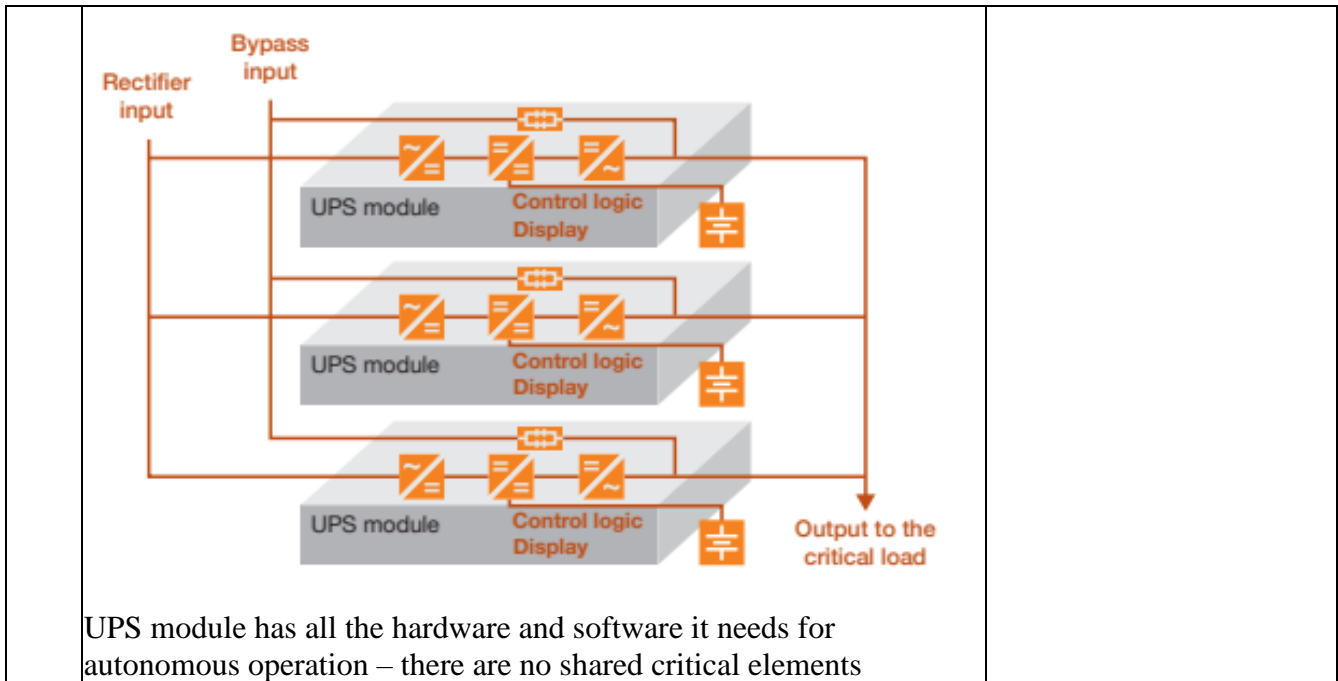

UPS module has all the hardware and software it needs for autonomous operation – there are no shared critical elements

3.	UPS frame rated power	250kW	
4.	UPS module rated power	20kW and above	
5.	Max. no of parallel frames	
6.	Max no of parallel modules across frames	
7.	Max system power	Minimum 1000 kW	
8.	Wiring	3ph + N + PE	
9.	Topology	True online double conversion, Decentralized Parallel Architecture	
10.	Starting	Cold start capacity	
11.	Maintenance bypass switch	Fitted	
12.	Built-in back-feed protection	Fitted	
13.	Parallel configuration	up to 5 UPS in parallel	
14.	Serviceability	Fully front serviceable	
	Input Specifications		
15.	Input voltage	3x380/220 V + N, 3x400/230 V + N, 3x415/240 V + N	
16.	Voltage tolerance (referred to 400/230 V)	For loads < 100 % (-10 %, +15 %), < 80 % (-20 %, +15 %), < 60 % (-30 %, +15 %)	
17.	Input distortion THDi	< 3% (at full load)	
18.	Frequency range	35–70Hz	
19.	Compatibility with power	Yes	

	supply units		
20.	Input power factor	> 0.99	
	Output Specifications		
21.	Output voltage	3x380/220 V + N, 3x400/230 V + N, 3x415/240 V + N	
22.	Voltage tolerance (referred to 400/230 V)	<±1% with static load / <±4% with step load	
23.	THD output voltage	<0.5% with linear load, <1% with non-linear load	
24.	UPS output rated PF	1.0	
25.	Double conversion	≥ 96%	
26.	Efficiency in Eco mode	≥ 99%	
27.	Nominal output frequency	50Hz ±2 % (standard)	
28.	Crest factor	03:01	
29.	Waveform	Sinusoidal	
30.	Overload capacity	10 minutes at 125%, 60 seconds at 150%	
31.	Bypass	Automatic bypass (static and electromechanical) and manual maintenance bypass	
32.	Load-sync for single units	To synchronize single units' output for no-break load transfers by downstream static transfer switches	
	Batteries System	Refer to ESS on Section XXII	(<i>Show workout</i>)
33.	Battery configuration	Flexible number, blocks and strings Batteries per String: _____? No of Strings _____? Total Batteries per UPS: _____?	
34.	Battery AH:		
35.	Discharge power (Watt) per cell for final voltage of 1.7V at 20C at 60 mins		
36.	Battery series type/voltage	high rate discharge maintenance free; VRLA (to support Li-On)	
37.	Battery duty cycle	Min 700 at 40% DOD	
38.	Autonomy	60 minutes (collaborate)	
39.	Load	125kW rating of the UPS	
40.	Battery charger	Decentralized charger per module	

41.	Warranty	12 months	
42.	Life of battery	10 years	
43.	Electrolyte Immobilization	The battery shall utilize absorbent glass mat (AGM) technology to immobilize electrolyte.	
44.	Plates	Both positive and negative plates shall be of the flat pasted plate design to ensure highly reliable electrical performance throughout the life of the battery.	
45.	Terminals	All batteries shall include copper inserted terminal posts allowing connector torque of 11Nm for M6, 13Nm for M8	
46.	Container	The cell container and cover shall be of a flame-retardant material with an oxygen index of at least 28.	
47.	Battery protection and safety	Must have both protective and safety isolation switch gear. To disconnect and protect an external battery pack (wall mounted box)	
48.	DC Cable	Copper (appropriate size)	
49.	Battery cabinet	Suitable rack sized	
	Communication and Management		
50.	User Interface	Module level LCD + mimic diagram System graphical touch screen (one per system)	
51.	Remote monitoring panel	To monitor UPS status by a LED panel from a remote control room	
52.	Communication ports	USB, RS-232, SNMP slot, potential-free contacts	
53.	Back feed protection	NC/NO auxiliary contact	
54.	Emergency Power Off (EPO)	Yes	
55.	Cold start push-button	Yes	
56.	Customer interface	Remote shutdown, gen-set interface, external bypass contact	
57.	Audible alarm	Beeping sound for Line Failure, Battery Low, Bypass - Overload Status, Fault Status	
58.	LED-Alarm	Line - Backup - Eco Mode, Bypass, Battery Low/Bad/Disconnect, Overload,	

		Fault	
	Mechanical characteristics		
59.	Weight	approx.kg (250kW system without batteries)	
60.	Dimensions WxHxD	
61.	Installable battery weight	
62.	Net weight kg	
63.	Provision of map		
	Ambient Conditions		
64.	Operating temperature/humidity	0 - 40°C / 0 - 95% non-condensing	
65.	Protection rating	IP20	
66.	Maximum audible noise at 1 m from the unit (dBA)	50-65	
67.	Altitude (above sea level)	1000m without de-rating	
	Conformity		
68.	Safety	IEC/EN 62040-1	
69.	EMC	IEC/EN 62040-2	
70.	Performance	IEC/EN 62040-3	
71.	Manufacturing	ISO 9001:2015, ISO 14001:2015, OHSAS18001	
	Services:		
72.	Installation	Modular architecture with “plug & play” power modules and batteries	
73.	Maintenance	Availability of optional services provided by the manufacturer	
74.	Ease of management	Advanced diagnostic functions via the touch screen display	

Tender's Signature _____ Official Stamp _____

Date _____

SECTION V – PRICE SCHEDULE FOR GOODS AND SERVICES

Note: This must be read in reference to guarantee specification above, detailed of services and attached drawing.

S/NO	DESCRIPTION	UNIT	QTY	WARRANTY / DELIVERY SCHEDULE	UNIT PRICE DDP VAT INCLUSIVE	TOTAL PRICE DDP VAT INCLUSIVE
	PART A : INSTALLATION OF UPS					
1.	Supply, installation, testing & commissioning of 250kW True online double conversion, Decentralized Parallel Architecture Modular UPS operating on 415V, 50 Hz, 3 phase input and 3 phase output , interconnecting suitable size copper cables between UPS & batteries, UPS input switch & UPS, UPS outgoing switch & UPS, UPS body & Body Earth, UPS neutral & neutral Earth as per actual site requirements.	No.	2			
2.	Supply and installation of Load-sync box for two sets of UPS To synchronize the output of two the UPS systems for no-break load transfers by downstream static transfer switches	No.	1			
3.	Supply, installation, testing & commissioning of SMF (seal maintenance free) battery bank for 2 x 250 kW True online double conversion, Decentralized Parallel Architecture Modular UPS for providing backup time of 120 mins & battery charger, battery stand with enclosure.	Set	2	Battery: No.: Type:		
4.	Spare parts : power modules	No.	2			
5.	Battery room to be supplied with appropriate Ventilation Fans (with EM filters), Securing with appropriate metal grills, roof and painting.	Lot	1			
	PART B : RELOCATION OF 4NO. UPSs					
6.	Relocation of Existing Units to 4No. Sites to be identified by KPLC; Installation to cater for Incomer Isolator, Interconnecting cables and Distribution Board	Lot	1			
	TOTAL					

N/B

1. All prices include transport and all the applicable taxes for Supply, Delivery, Installation and Testing of 250 KW UPS
2. Delivery shall be made to Electricity House Nairobi.
3. FAT and inspection will be carried out at the OEMs site before shipment.

SECTION VI - EVALUATION CRITERIA

Evaluation of duly submitted tenders will be conducted along the following stages: -

6.1 Part 1 - Preliminary Evaluation Under Paragraph 3.28 of the ITT. These are mandatory requirements. This shall include confirmation with documentary proof of the following: -

6.1.1 *Submission of Tender Security - Checking its validity, whether it is Original; whether it is issued by a local bank/institution; whether it is strictly in the format required in accordance with the sample Tender Security Form(s).*

6.1.2 *Submission of Declaration Form(s) duly completed and signed.*

6.1.3 *Submission and considering Tender Form duly completed and signed.*

6.1.4 *Submission and considering the following:-*

6.1.4.1 *For Local Tenderers*

a) *Company or Firm's Registration Certificate*

b) *PIN Certificate.*

c) *Valid Tax Compliance Certificate.*

d) *Names with full contact as well as physical addresses of previous customers of similar goods and reference letters from at least four (4) previous customers.*

6.1.4.2 *For Foreign Tenderers*

a) *Company or Firm's Registration Certificate*

b) *PIN Certificate or its equivalent in the country of bidder or a statement from the tax authorities in the Tenderer's country of origin indicating that such certificate or its equivalent is not issued.*

c) *Valid Tax Compliance Certificate or its equivalent in the country of bidder or a statement from the tax authorities in the Tenderer's country of origin indicating that such certificate or its equivalent is not issued.*

d) *Names with full contact as well as physical addresses of previous customers of similar goods and reference letters from at least four (4) previous customers.*

6.1.5 *That the Tender is valid for the period required.*

6.1.6 *Submission and considering the Confidential Business Questionnaire:-*

a) *Is fully filled.*

b) *That details correspond to the related information in the bid.*

c) *That the Tenderer is not ineligible as per paragraph 3.2 of the ITT.*

6.1.7 *Record of unsatisfactory or default in performance obligations in any contract shall be considered. This shall include any Tenderer with unresolved case(s) in its performance obligations for more than two (2) months in any contract.*

6.1.8 *Notwithstanding the above, considering any outstanding orders/Supplier Performance Review Scheme (SPRS) where applicable and the performance capacity indicated by the Tenderer.*

Tenders will proceed to the Technical Evaluation Stage only if they qualify in compliance with Part 1 above, Preliminary Evaluation under Paragraph 3.28.

6.2 Part II - Technical Evaluation Criteria Under Paragraph 3.30 of the ITT.

The detailed technical evaluation consists of the following:

Parts II (a) – These are mandatory requirements

6.2.1 Evaluation of the following technical information against Tender Requirements and Specifications: -

6.2.1.1 Fully filled Schedule of Guaranteed Technical Particulars as per Technical Specifications.

6.2.1.2 The tenderer must be registered with National Construction Authority (NCA 1-3) class (Electrical Engineering Service Contractor).

6.2.1.3 Class of Licenses with the relevant statutory bodies, Class A-B registration as an electrical contractor with the Energy Regulatory & Petroleum Authority/ Ministry of Energy.

6.2.1.4 The bidder submits the following from the UPS manufacturer (OEMs): –

- a) Manufacturer's Authorization
- b) Manufacturer's Warranty
- c) Manufacturer's/ Principal's valid quality management system certification i.e. ISO 9001 or KEBS Diamond Mark of Quality Certificate
- d) Type Test Certificates and their Reports or Test Certificates and their Reports from the designated bodies for full compliance with Tender Specifications
- e) OEM minimum of 20 years' experience in the design, manufacture and testing of solid-state UPS systems.
- f) Battery warranty indicating with proper illustration on how backup is achieved.
- g) The accreditation certificate for the testing body to ISO/ IEC 17025.
- h) Confirm that the products quoted are not end of life products
- i) Replacement Parts Stocking; Parts will be available in-country; the various channels and partners will ensure that the parts are available 24x7x365 throughout the country.
- j) Catalogues and or Brochures and or Manufacturer's drawings

6.2.1.5 Site/survey visit signed and stamped form by authorized staff for all the sites.

KPLC may contact and verify bidder's information, references and data submitted.

Tenderers will proceed to the next evaluation stage if they qualify in compliance with Parts II (a) above.

Part II (b) - Technical Evaluation under clause 3.20 of the ITT.

It will include the following stages: The following will be scored.

6.2.2 Detailed Technical Evaluation

NO.	EVALUATION CRITERIA	Maximum Marks			PG
6.2.2.1	<p><i>Previous experience: Details of similar Contracts (Supply and installation of above 80kVA UPS) undertaken successfully within the last 5 years and evidenced by letters of reference from clients, completion certificates for the respective projects up to maximum 5 No. Projects. (Attach Evidence of completion certificates)</i></p> <p><i>Project with value of over KShs. 30 million - Score 4</i></p> <p><i>Project with value of over KShs. 20 million - Score 2</i></p> <p><i>Project with value of over KShs. 10 million - Score 1</i></p>	20			
6.2.2.2	<p><i>Customer Feedback:</i></p> <p><i>Satisfactory service feedback by customer (for installations above 80kVA UPS). For each customer Feedback report bidder will get four (2) marks</i></p> <p><i>Customer feedback by 2 clients (Score 4)</i></p> <p><i>Customer feedback by 3 clients (Score 6)</i></p> <p><i>Customer feedback by 5 clients (Score 10)</i></p>	10			
6.2.2.3	<p><i>Number of years in the business of supply and installation of UPSs, evidenced by completion certificate.</i></p>	10	>10yrs	10	
			>yrs	6	
			<5yr	2	
6.2.2.4	<p><i>Qualified Key personnel as required under clause 3.20.2 in the tender relevant to the works who will actively be involved in the proposed contract.</i></p> <p><i>Engineer/technician trained by OEM of intended product to be supplied (each Score 5)</i></p> <p><i>Any other Engineers/technicians (each Score 2)</i></p> <p><i>(Provide evidence, Telephone contacts must be provided)</i></p>	20			
		<p>5 scores for each Engineer/technicians up to 4 or more.</p>			

6.2.2.5	<p><i>Compliance with Technical Specifications, Identifying and determining any deviation(s) from the requirements, Considering test reports;</i></p> <p><i>i. UPS indicating Brand, Model/ Country of origin as per specification in the tender (10 score)</i></p> <p><i>ii. Battery indicating Brand, Model/ Country of origin as per specification in the tender, with proper illustration on how backup is achieved(10 score)</i></p> <p><i>iii. Submission of working drawings (battery arrangement, cabling & UPS) prepared with full site understanding (5 score)</i></p>	25	
6.2.2.6	<p><i>Equipment. Give a list and type of relevant equipment owned by the company evidenced by ownership documents. Where not owned by the company, provide documentary evidence of leased equipment.</i></p>	5	
6.2.2.7	<p><i>Electrical Contractor</i></p> <p><i>i)Registration with NCA for the respective Category/Class</i></p> <p><i>ii)Certificate of Registration under Company’s Act</i></p> <p><i>iii)Valid Tax Compliant Certificate</i></p> <p><i>iv) ICT authority certificate of accreditation</i></p> <p><i>v) ERPA/ERC certificate</i></p>	5	
6.2.2.8	<p><i>Proof of local Service Centre with proactive support</i></p>	5	
	TOTAL	100	

Note:

Tenderers will proceed to Financial Evaluation stage only if they score a minimum score of 75% in Parts II (b) above.

6.3 Part III – Financial Evaluation Criteria Under Paragraph 3.31 of the ITT. These are mandatory requirements.

6.3.1 This will include the following: -

- a) *Confirmation of the authenticity and sufficiency of the submitted Tender Security.*
- b) *Confirmation of and considering Price Schedule duly completed and signed.*
- c) *Checking that the Tenderer has quoted prices based on all costs including duties and taxes*
- d)* *Checking submission of audited financial statements required which must be those that are reported within eighteen (18) calendar months of the date of the tender document.*
- e) *Conducting a financial comparison, including conversion of tender currencies into one common currency,*
- f) *Taking into account the cost of any deviation(s) from the tender requirements,*
- g) *Considering information submitted in the Confidential Business Questionnaire against other information in the bid including: -*
 - a) *Declared maximum value of business*
 - b) *Shareholding and citizenship for preferences where applicable.*
- h) *Apply Exclusive margin of preference, where applicable as per Clause 3.32 of the tender document*

6.3.2 Confirming the following: -

6.3.2.1 that the Supplier's offered Delivery Schedule meets KPLC's requirements.

6.3.2.2 that the Supplier's offered Terms of Payment meets KPLC's requirements.

6.4 The Successful Tenderer shall be the lowest bidder and technically compliant .

***NOTES: -**

1. For purposes of evaluation, the exchange rate to be used for currency conversion shall be the selling exchange rate ruling on the date of tender closing provided by the Central Bank of Kenya. (Visit the Central Bank of Kenya website).
2. Total tender value means the Tenderer's total tender price inclusive of Value Added Tax (V.A.T) for the services it offers to provide.
3. For companies or firms that are registered or incorporated within the last one calendar year of the Date of the Tender Document, they should submit certified copies of bank statements covering a period of at least six months prior to the date of the tender document. The copies should be certified by the Bank issuing the statements. The certification should be original.
4. The spot balance of 20% required will be that which is seen in the certified bank statements at least in any day of the month of the Date of the Tender Document.
5. Due Diligence Evaluation for Technically Compliant Bidders

Prior to approval of recommended applicants, KPLC shall carry-out due diligence to determine suitability and competence of bidders recommended to offer the services. The inspection will include but not limited to:

- Checking the physical office of the bidders
- Confirming availability of competent personnel as declared by the bidder and payroll inspection adhering to minimum wage
- Verification of ALL statutory documents, checking of relevant equipment, handling of waste, including confirmation of details stated on forwarded documents, and whether they correspond to physical details. These shall include and are not limited to production capacity, Tools & Equipment, space, certificates etc.
- Checking any other critical item as may be decided by the evaluation committee ie the bidder's experience or if newly established, the experience of the founding/mother company. This will entail carrying out due diligence on the mother company too.
- Capacity of manufacturer to design, supply and installation of high capacity solid-state UPS systems.

TABLE OF CLAUSES ON GENERAL CONDITIONS OF CONTRACT

Clause No.	Headings	Page No.
7.1	Definitions	39
7.2	Application.....	40
7.3	Standards.....	40
7.4	Supplier Performance Rating Scheme	40
7.5	Use of Contract Documents and Information	40
7.6	Patent Rights	41
7.6	Performance Security	41
7.7	Inspection and Tests.....	42
7.8	Packaging and Labelling.....	42
7.9	Delivery and Documents for Materials/ Equipment	43
7.10	Insurance	43
7.11	Payment	44
7.12	Interest	44
7.13	Prices.....	45
7.14	Variation of Contract	45
7.15	Assignment	45
7.16	Subcontracts.....	45
7.17	Termination of Contract.....	45
7.18	Liquidated Damages	46
7.19	Warranty	46
7.20	Resolution of Disputes	47
7.21	Language and Law	47
7.22	Waiver.....	47
7.23	Force Majeure	47

SECTION VII – GENERAL CONDITIONS OF CONTRACT

The General Conditions of Contract *hereinafter referred abbreviated as the GCC* shall form part of the Conditions of Contract in accordance with the law and KPLC's guidelines, practices, procedures and working circumstances. The provisions in the GCC will apply unless an alternative solution or amendment is made under other parts of the Contract including the Special Conditions of Contract.

7.1 Definitions

In this contract, the following terms shall be interpreted as follows: -

- a) *“Day” means calendar day and “month” means calendar month.*
- b) *“The Contract” means the agreements entered into between KPLC and the Contractor, as recorded in the Contract Form signed by the parties, including all attachments and appendices thereto and all documents incorporated by reference therein.*
- c) *“The Contract Price” means the price payable to the Contractor under the contract for the full and proper performance of its contractual obligations.*
- d) *“The Services” means services or art thereof to be provided by the Contractor and includes all of the materials and incidentals, which the Contractor is required to perform and provide to KPLC under the contract.*
- e) *“The Procuring Entity” means The Kenya Power and Lighting Company Limited or its successor(s) and assign(s) where the context so admits (hereinafter abbreviated as KPLC).*
- f) *“The Contractor” means the individual or firm providing the services under this contract or his/ her/ its permitted heir(s), personal representative(s), successor(s) or permitted assign(s) where the context so admits. For the avoidance of doubt this shall mean the successful Tenderer(s) pursuant to the tender.*
- g) *Wherever used in the contract, “performance” shall be complete or be deemed to be complete, unless the circumstances indicate otherwise, when the services have been performed in accordance with the Contract and where KPLC does not signify its approval to the Contractor, but without giving notice of dissatisfaction, on the expiration of thirty (30) days from date of documented completion of performance of the service.*
- h) *Supplier Rating Performance Scheme (SPRS) means the continuous evaluation of the Supplier's performance of the contract based on the*

parameters of timely delivery, quality of service, frequency of communication, timely response, innovation, dispute resolution.

7.2 Application

These General Conditions shall apply to the extent that provisions of other parts of the contract do not supersede them.

7.3 Standards

The Services supplied under this contract shall conform to the standards mentioned in the Details of Service.

7.4 Supplier Performance Rating Scheme

7.4.1 KPLC shall use a Supplier Performance Rating Scheme (SPRS) to measure the annual performance of the Supplier's obligations and its conduct of the contract.

7.4.2 The Scheme will be updated periodically commencing with the date of execution of the contract by both parties. KPLC shall provide the Supplier with a copy of the SPRS report.

7.4.3 KPLC shall consider the Supplier's overall performance at the end of the performance period.

7.4.4 At the request of either party, the parties shall discuss and conclude deliberations on the annual SPRS report. At any such meetings and/or for the purposes of the deliberations, KPLC Supply Chain – Procurement Department shall appoint the Chairperson as well as the Secretariat.

7.4.5 The SPRS measures shall be according to Supplier Performance Rating Form in Section XXVI

7.4.6 A KP1, KP2 & KP3 assessment of the Supplier on the SPRS will be a consideration for continued engagement between the parties in the subsequent year. A KP4 assessment of the Supplier shall be a termination event.

7.5 Use of Contract Documents and Information

7.5.1 The Contractor shall not, without KPLC's prior written consent, disclose the contract, or any provision thereof or any specification, plan, drawing, pattern, sample, or information furnished by or on behalf of KPLC in connection therewith, to any person other than a person employed by the Contractor in the performance of the contract.

7.5.2 The Contractor shall not, without KPLC's prior written consent, make use of any document or information enumerated in clause 7.5.1 above.

7.5.3 Any document, other than the contract itself, enumerated in clause 7.5.1 shall remain the property of KPLC and shall be returned (including all copies) to KPLC

on completion of the Contractor's performance under the contract if so required by KPLC.

7.6 Patent Rights

The Contractor shall indemnify KPLC against all third party claims of infringement of patent, trademark, or industrial design rights arising from provision of the services or any part thereof.

7.6 Performance Security

- 7.6.1 Within fourteen (14) days of the date of the notification of contract award, the Contractor shall furnish to KPLC the Performance Security which shall be either one or a combination of the following:-
- a) An original Bank Guarantee that is strictly in the form and content as prescribed in the Performance Security Form (Bank Guarantee) in the Tender Document.
 - b) Confirmed Standby Letters of Credit (LC). All costs, expenses and charges levied by all banks party to the LC including confirmation charges shall be prepaid by the successful Tenderer. Certain mandatory conditions of the LC shall be as prescribed in the Performance Security Form (LC) in the Tender Document.
- 7.6.2 The Performance Security shall be issued by a commercial bank licensed by the Central Bank of Kenya. The bank must be located in Kenya.
- 7.6.3 The Performance Security shall be the sum of ten percent (10%) of the contract price. It shall be in the currency of the contract price.
- 7.6.4 Failure of the Contractor to furnish the Performance Security, the award shall be annulled and the Tender Security forfeited, in which event KPLC may notify the next lowest evaluated Tenderer that its Tender has been accepted.
- 7.6.5 The proceeds of the Performance Security shall be payable to KPLC as compensation for any loss resulting from the Contractor's failure to comply with its obligations in accordance with the contract without KPLC being required to demonstrate the loss it has suffered.
- 7.6.6 The Performance Security shall be valid for a minimum of sixty (60) days after satisfactory delivery for both Foreign and Local Contractors.
- 7.6.7 KPLC shall seek authentication of the Performance Security from the issuing bank. It is the responsibility of the Contractor to sensitize its issuing bank on the need to respond directly and expeditiously to queries from KPLC. The period for response shall not exceed three (3) days from the date of KPLC's query. Should there be no conclusive response by the Bank within this period, such Contractor's Performance Security may be deemed as invalid and the Contract nullified, unless information to the contrary is received by KPLC two (2) days before the expiry of the Contractor's Tender Security.
- 7.6.8 Subject to the provisions of this contract, the Performance Security will be discharged by KPLC and returned to the Contractor not earlier than thirty (30)

days following the date of completion of the Contractor's obligations under the contract, including any warranty obligations, under the contract.

7.7 Inspection and Tests

- 7.7.1 KPLC or its representative(s) shall have the right to inspect and/or to test the services to confirm their conformity to the contract specifications. KPLC shall notify the Contractor in writing in a timely manner, of the identity of any representative(s) retained for these purposes. Such visit and or inspection/ test shall in no way prejudice KPLC's rights and privileges.
- 7.7.2 In appropriate circumstances, Inspection/ Test Report(s) shall be completed upon conclusion of the inspection/ tests.
- 7.7.3 The inspections and tests may be conducted in the premises of the Contractor or its subcontractor(s). If conducted on the premises of the Contractor or its subcontractor(s), all reasonable facilities and assistance, including access to drawings and production data, shall be furnished to the inspectors at no charge to KPLC.
- 7.7.4 Should any inspected or tested services fail to conform to the specifications, KPLC may reject the Service(s), and the Contractor shall either replace or remedy the rejected services or make alterations necessary to meet specification requirements free of cost to KPLC.
- 7.7.5 KPLC's right to inspect, test and where necessary, reject the services after provision shall in no way be limited or waived by reason of the services having previously been inspected, tested and passed by KPLC or its representative(s) prior to the services performance / delivery.
- 7.7.6 For the avoidance of doubt, any acknowledgement by KPLC on the Contractor's or sub-contractor's document shall not be conclusive proof or evidence of satisfactory performance without duly authorized approval by KPLC.
- 7.7.7 Nothing in this clause 7.7 shall in any way release the Contractor from any warranty or other obligations under this Contract.

7.8 Packaging and Labelling

- 7.8.1 Where applicable, the Contractor shall provide such packaging of the material and equipment as is required to prevent their damage or deterioration during transit to their final destination, as indicated in the contract.
- 7.8.2 The method of packaging, labeling and marking shall comply strictly with such special requirements as shall be specified and attached to the Contract and particular Order.

7.8.3 The labelling, marking and documentation within and outside the packages shall comply strictly with such special requirements as shall be expressly provided for in the contract.

7.8.4 The materials and equipment shall be packed in good condition suitable for sea/air/road/rail dispatch. Hazard in transit to the final destination shall include rough handling and storage in tropical conditions.

7.8.5 The Contractor shall enclose a packing list in each package and all documents relating to the Order shall show the Tender reference number and name against the items or package indicating the supplier or supplier's agent as the consignee.

7.9 Delivery and Documents for Materials/ Equipment

7.9.1 Where applicable, delivery of the materials/ equipment shall be made by the Contractor to the place and in accordance with the terms specified by KPLC in its Schedule of Requirements or as may be otherwise indicated.

7.9.2 The Contractor shall notify KPLC of the full details of the delivered materials/ equipment by delivering the materials/ equipment with a full set of the following documents: -

- a) *Contractor's invoice showing the materials/ equipment description, quantity, unit price and total price*
- b) *Delivery note*
- c) *Packing list identifying contents of each package*

7.9.3 It is the responsibility of the Contractor to ensure that the delivery documents are received by KPLC at the designated delivery point at the time of delivery.

7.10 Insurance

7.10.1 The Contractor shall be responsible for and keep in force current appropriate insurance covers for its property and persons engaged in the performance and or provision of the Services under the contract.

7.10.2 The Contractor shall (*except in respect to losses, injuries or damage resulting from any act or neglect of KPLC*) indemnify and keep indemnified KPLC against all losses and claims for injuries or damage to any person or property whatsoever

which may arise out of or in consequence of the contract and against all claims, demands, proceedings, damages, costs, charges, and expenses whatsoever in respect thereof or in relation thereto.

7.11 Payment

- 7.11.1 Payments shall be made promptly by KPLC and shall not be less than thirty (30) days from completion of satisfactory performance and submission of invoice together with other required and related documents or as otherwise prescribed in the contract.
- 7.11.2 Payment shall primarily be through KPLC's cheque or Real Time Gross Settlement (RTGS) or telegraphic transfer. Where applicable, a copy of a valid Performance Security, stamped, certified as authentic by KPLC, shall form part of the documents to be presented to KPLC before any payment is made.
- 7.11.3 A Contractor who requests for a Letter of Credit (*hereinafter abbreviated as LC*)–
- a) *Shall meet the LC bank charges levied by its bank while KPLC shall meet the LC bank charges levied by its bank.*
 - b) *Any extension and or amendment charges and any other costs that may result from the Contractor's delays, requests, mistakes or occasioned howsoever by the Contractor shall be to the Beneficiary's account.*
 - c) *The maximum number of extensions and amendments shall be limited to two (2).*
 - d) *Notwithstanding sub-clause 7.11.3 (a), should the Contractor require a confirmed LC, then all confirmation and any other related charges levied by both the Contractor's and KPLC's bank shall be to the Beneficiary's account.*
 - e) *The LC shall be opened only for the specific Order within the validity period of the contract.*
 - f) *LCs shall be partial for partial performance or full for whole performance as per the contract.*
 - g) *The Contractor shall be required to submit a proforma invoice for each lot for use in the placement of order and opening of the LC. The proforma invoice shall be on total all-inclusive costs basis.*
 - h) *A copy of the Performance Security, stamped and certified as authentic by KPLC, whose expiry date should not be less than sixty (60) days from the LC expiry date, shall form part of the documents to be presented to the Bank before any payment is effected.*
- 7.11.4 KPLC shall have the sole discretion to accept or decline any Contractor's payment request through Letters of Credit without giving any reason for any decline.

7.12 Interest

Interest payment by KPLC is inapplicable in the contract.

7.13 Prices

- 7.13.1 Subject to clause 7.14 herein below, prices charged by the Contractor for services performed under the contract shall be fixed for the period of the contract with no variations.
- 7.13.2 A price that is derived by a pre-disclosed incorporation or usage of an internationally accepted standard formula shall not be deemed to be a price variation within the meaning of this clause.

7.14 Variation of Contract

KPLC and the Supplier may vary the contract only in accordance with the following: -

- a) *the quantity variation of services shall not exceed twenty percent (20%) of the original contract quantity.*
- b) *The cumulative value variation shall not exceed twenty five percent (25%) of the original contract value.*
- c) *the quantity variation must be executed within the period of the contract.*

7.15 Assignment

The Contractor shall not assign in whole or in part its obligations to perform under this contract, except with KPLC's prior written consent.

7.16 Subcontracts

- 7.16.1 The Contractor shall notify KPLC in writing of all subcontracts awards under this contract if not already specified in the tender. Such notification, in the original tender or obligation under the Contract shall not relieve the Contractor from any liability or obligation under the Contract.
- 7.16.2 In the event that an award is given and the contract is sub-contracted, the responsibility and onus over the contract shall rest on the Contractor who was awarded.

7.17 Termination of Contract

- 7.17.1 KPLC may, without prejudice to any other remedy for breach of contract, by written notice sent to the Contractor, terminate this contract in whole or in part due to any of the following: -
- a) *if the Contractor fails to perform any or all of the services within the period(s) specified in the contract, or within any extension thereof granted by KPLC.*
 - b) *if the Contractor fails to perform any other obligation(s) under the contract.*
 - c) *if the Contractor, in the judgment of KPLC has engaged in corrupt or fraudulent practices in competing for or in executing the contract.*
 - d) *by an act of force majeure.*

- e) *if the Contractor becomes insolvent or bankrupt*
- f) *if the Contractor has a receiving order issued against it, compounds with its creditors, or an order is made for its winding up (except for the purposes of its amalgamation or reconstruction), or a receiver is appointed over its or any part of its undertaking or assets, or if the Contractor suffers any other analogous action in consequence of debt.*
- g) *if the Contractor abandons or repudiates the Contract.*

7.17.2 In the event that KPLC terminates the contract in whole or in part, it may procure, upon such terms and in such manner as it deems appropriate, services similar to those undelivered or not rendered, and the Contractor shall be liable to KPLC for any excess costs for such similar services and or any other loss PROVIDED that the Contractor shall not be so liable where the termination is for convenience of KPLC.

7.17.3 The Parties may terminate the Contract by reason of an act of *force majeure* as provided for in the contract.

7.17.4 The Contract may automatically terminate by reason of an act of *force majeure* as provided for in the Contract.

7.18 Liquidated Damages

Notwithstanding and without prejudice to any other provisions of the contract, if the Contractor fails to perform any or all of the services within the period specified in the contract, KPLC shall, without prejudice to its other remedies under the contract, deduct from the contract prices, liquidated damages sum equivalent to 0.5% of the performance price per day of delay of the delayed due services up to a maximum of ten percent (10%) of the performance price of the delayed due services.

7.19 Warranty

7.19.1 Where applicable, the Contractor warrants that the Services provided under the contract are of the highest quality or current specification and incorporate all recent improvements unless provided otherwise in the contract. The Contractor further warrants that any materials/ equipment provided under this contract shall have no defect arising from manufacture, materials or workmanship or from any act or omission of the Contractor that may develop under normal use of the materials/ equipment provided under the conditions obtaining in Kenya.

7.19.2 This warranty will remain valid for the period indicated in the special conditions of contract after the goods, or any portion thereof as the case may be, have been delivered to the final destination indicated in the contract.

- 7.19.3 KPLC shall promptly notify the Contractor in writing of any claims arising under this Warranty.
- 7.19.4 Upon receipt of such a notice, the Contractor shall, with all reasonable speed, remedy the defective services without cost to KPLC.
- 7.19.5 If the Contractor having been notified, fails to remedy the defect(s) within a reasonable period, KPLC may proceed to take such remedial action as may be necessary, at the Contractor's risk and expense and without prejudice to any other rights which KPLC may have against the Contractor under the contract.

7.20 Resolution of Disputes

- 7.20.1 KPLC and the Contractor may make every effort to resolve amicably by direct informal negotiation any disagreement or dispute arising between them under or in connection with the contract.
- 7.20.2 If, after thirty (30) days from the commencement of such informal negotiations both parties have been unable to resolve amicably a contract dispute, either party may resort to resolution before a recognized local forum for the resolution of disputes.

7.21 Language and Law

The language of the contract and the law governing the contract shall be the English language and the laws of Kenya respectively unless otherwise stated.

7.22 Waiver

Any omission or failure by KPLC to exercise any of its rights or enforce any of the penalties arising from the obligations imposed on the Contractor shall in no way, manner or otherwise howsoever, alter, amend, prejudice, vary, waive or be deemed to alter, amend, prejudice, vary, waive or otherwise whatsoever any of KPLC's powers and rights as expressly provided in and as regards this contract.

7.23 Force Majeure

- 7.23.1 Force majeure means any circumstances beyond the control of the parties, including but not limited to:
- a) *war and other hostilities (whether war be declared or not), invasion, act of foreign enemies, mobilization, requisition or embargo;*
 - b) *ionizing radiation or contamination by radio-activity from any nuclear fuel or from any nuclear waste from the combustion of nuclear fuel, radioactive toxic explosives or other hazardous properties of any explosive nuclear assembly or nuclear components thereof;*
 - c) *rebellion, revolution, insurrection, military or usurped power & civil war;*
 - d) *riot, commotion or disorder except where solely restricted to employees servants or agents of the parties;*

e) *un-navigable storm or tempest at sea.*

- 7.23.2 Notwithstanding the provisions of the contract, neither party shall be considered to be in default or in breach of its obligations under the Contract to the extent that performance of such obligations is prevented by any circumstances of *force majeure* which arise after the contract is entered into by the parties.
- 7.23.3 If either party considers that any circumstances of *force majeure* are occurring or have occurred which may affect performance of its obligations it shall promptly notify the other party and provide reasonable proof of such circumstances.
- 7.23.4 Upon the occurrence of any circumstances of *force majeure*, the Contractor shall endeavour to continue to perform its obligations under the contract so far as is reasonably practicable. The Contractor shall notify KPLC of the steps it proposes to take including any reasonable alternative means for performance, which is not prevented by *force majeure*. The Contractor shall not take any such steps unless directed so to do by KPLC.
- 7.23.5 If the Contractor incurs additional costs in complying with KPLC's directions under sub clause 7.23.4, then notwithstanding the provisions of the contract, the amount thereof shall be agreed upon with KPLC and added to the contract price.
- 7.23.6 If circumstances of *force majeure* have occurred and shall continue for a period of twenty one (21) days then, notwithstanding that the Contractor may by reason thereof have been granted an extension of time for performance of the contract, either party shall be entitled to serve upon the other seven (7) days' notice to terminate the contract. If at the expiry of the period of twenty-eight (28) days, *force majeure* shall still continue, the contract shall terminate.

SECTION VIII – SPECIAL CONDITIONS OF CONTRACT

The Special Conditions of Contract *hereinafter abbreviated as SCC* shall form part of the Conditions of Contract. They are made in accordance with the law and KPLC’s guidelines, practices, procedures and working circumstances. They shall amend, add to and vary the GCC. The clauses in this section need not therefore, be completed but must be completed by KPLC if any changes to the GCC provisions are deemed necessary. Whenever there is a conflict between the GCC and SCC, the provisions of the SCC shall prevail over those in the GCC.

No.	GCC Reference Clause	Particulars of SCC
1.	Terms of Payment	The company will pay the supplier within 30 days from submission of invoice.
2.	Warranty Period	1 year
3.	Completion Period for the works (in weeks)	TO BE INSERTED BY THE TENDERER
4.	Performance Bond	Bidders is required to provide a Performance Security amounting to 10% of the total contract price.

Tender’s Signature _____ Official Stamp _____

Date _____

SECTION IX - TENDER FORM

Date:
Tender No.

To:

The Kenya Power & Lighting Company Limited,
Stima Plaza,
Kolobot Road, Parklands,
P.O Box 30099 – 00100,
Nairobi, Kenya.

Ladies and Gentlemen,

1. Having read, examined and understood the Tender Document including all Addenda, receipt of which we hereby acknowledge, we, the undersigned Tenderer, offer to provide(insert services description) for the sum of.....(total tender price in words and figures) in accordance and conformity with the said tender document and in particular the Schedule of Prices that are made part of this Tender.
2. We undertake, if our Tender is accepted, to perform and provide the services in accordance with the Schedule of Requirements.
3. If our Tender is accepted, we will obtain the guarantee of a bank in a sum of equivalent to ten percent (10%) of the contract price for the due performance of the contract, in the form(s) prescribed by The Kenya Power & Lighting Company Limited.
4. We agree to abide by this Tender for a period of.....days (**Tenderer please indicate validity of your Tender**) from the date fixed for tender opening as per the Tender Document, and it shall remain binding upon us and may be accepted at any time before the expiration of that period.
5. This Tender, together with your written acceptance thereof and your notification of award, shall not constitute a contract, between us. The contract shall be formed between us when both parties duly sign the written contract.
6. We understand that you are not bound to accept any Tender you may receive.

Yours sincerely,

Name of Tenderer

Signature of duly authorised person signing the Tender

Name and Designation of duly authorised person signing the Tender

Stamp or Seal of Tenderer

***NOTES:**

1. KPLC requires a validity period of at least one hundred and eighty (180) days.
2. This form must be duly signed, stamped and/or sealed.

SECTION X - CONFIDENTIAL BUSINESS QUESTIONNAIRE FORM

All Tenderers are requested to give the particulars indicated in Part 1 and either Part 2 (a), 2 (b) or 2 (c), whichever applies to your type of business. You are advised that it is a serious offence to give false information on this form.

Part 1 – General

Business Name.....

Location of business premises.....

Plot No.Street/ Road

Postal Address Postal Code

Tel No.....

Facsimile.....

Mobile and/ or CDMA No.....

E-mail:.....

Nature of your business

Registration Certificate No.....

Maximum value of business which you can handle at any time KSh.....

Name of your BankersBranch... ..

*Names of Tenderer’s contact person(s)

Designation of the Tenderer’s contact person(s)

Address, Tel, Fax and E-mail of the Tenderer’s contact person(s)

.....
.....

Part 2 (a) Sole Proprietor

Your name in full

NationalityCountry of origin

*Citizenship details.....

Part 2 (b) Partnership

Give details of partners as follows: -

Names	Nationality	*Citizenship Details	Shares
-------	-------------	----------------------	--------

1.....

2.....

3.....

4.....

5.....

Part 2 (c) Registered Company

Private or Public

State the nominal and issued capital of company-

Nominal KSh.....

Issued KSh.....

Give details of all directors as follows

Name	Nationality	*Citizenship Details	Shares
------	-------------	----------------------	--------

1.....

2.....

3.....

4.....

5.....

Name of duly authorized person to sign for and on behalf of the Tenderer

.....

Designation of the duly authorized person.....

Signature of the duly authorized person.....

***NOTES TO THE TENDERERS ON THE QUESTIONNAIRE**

1. *The address and contact person of the Tenderer provided above shall at all times be used for purposes of this tender.*
2. *If a Kenyan citizen, please indicate under “Citizenship Details” whether by birth, naturalization or registration.*
3. *The details on this Form are essential and compulsory for all Tenderers. **Failure to provide all the information requested shall lead to the Tenderer’s disqualification.***
4. *For foreign Tenderers please give the details of nominal and issued share capital in the currency of the country of origin of the Tenderer.*

SECTION XI A - TENDER SECURITY FORM – (BANK GUARANTEE)

(To Be Submitted On Bank’s Letterhead)

Date:

To:

The Kenya Power & Lighting Company Limited,
Stima Plaza,
Kolobot Road, Parklands,
P.O Box 30099 – 00100,
Nairobi, Kenya.

WHEREAS (*name of the Tenderer*) (*hereinafter called “the Tenderer”*) has submitted its Tender dated for the supply, installation and commissioning of..... (*please insert KPLC tender no. and name*) (*hereinafter called “the Tender”*);

KNOW ALL PEOPLE by these presents that **WE**.....ofhaving our registered office at.....(*hereinafter called “the Bank”*), are bound unto The Kenya Power and Lighting Company Limited (*hereinafter called “KPLC” which expression shall where the context so admits include its successors-in-title and assigns*) in the sum of for which payment well and truly to be made to the said KPLC, the Bank binds itself, its successors, and assignees by these presents.

We undertake to pay you, upon your first written demand declaring the Tenderer to be in breach of the tender requirements and without cavil or argument, the entire sum of this guarantee being (*amount of guarantee*) as aforesaid, without you needing to prove or to show grounds or reasons for your demand or the sum specified therein.

This tender guarantee will remain in force up to and including thirty (30) days after the period of tender validity, and any demand in respect thereof should reach the Bank not later than the date below.

This guarantee is valid until theday of.....20.....

EITHER

SEALED with the)
COMMON SEAL)

of the said **BANK**) _____

thisday) BANK SEAL
 of20....)
)
 in the presence of :-)
)
 _____)
)
 and in the presence of:-)
)
 _____)

OR

SIGNED by the **DULY AUTHORISED**
REPRESENTATIVE(S)/ ATTORNEY(S) of
 the **BANK**

 Name(s) and Designation of duly authorised representative(s)/ attorney(s) of the Bank

 Signature(s) of the duly authorised person(s)

NOTES TO TENDERERS AND BANKS

1. *Please note that no material additions, deletions or alterations regarding the contents of this Form shall be made to the Tender Security to be furnished by the Tenderer. If any are made, the Tender Security shall not be accepted and shall be rejected by KPLC. For the avoidance of doubt, such rejection will be treated as non-submission of the Tender Security where such Security is required in the tender.*
2. *It is the responsibility of the Tenderer to sensitize its issuing bank on the need to respond directly and expeditiously to queries from KPLC. The period for response shall not exceed three (3) days from the date of KPLC's query. Should there be no conclusive response by the Bank within this period, such Tenderer's Tender Security shall be deemed as invalid and the bid rejected.*
3. ***The issuing bank should address its response or communication regarding the bond to KPLC at the following e-mail address – “guarantees@kplc.co.ke”***
4. *The Tender validity period is one hundred and eighty (180) days as set out in the Invitation to Tender (at Section I of the Tender document) or as otherwise may be extended by KPLC. Therefore the Tender Security must at all times be valid for at least 30 days beyond the tender validity period.*

**SECTION XI B - TENDER SECURITY FORM (SACCO SOCIETY, DEPOSIT
TAKING MICRO FINANCE INSTITUTIONS, WOMEN ENTERPRISE FUND &
YOUTH ENTERPRISE FUND)**

(To Be Submitted On Institutions Letterhead)

Date:

To:

The Kenya Power & Lighting Company Limited,
Stima Plaza,
Kolobot Road, Parklands,
P.O Box 30099 – 00100,
Nairobi, Kenya.

WHEREAS.....(hereinafter called “the Contractor”) has undertaken, in pursuance of your Tender Number.....(*reference number of the Tender*) and its Tender dated(*insert Contractor’s date of Tender taken from the Tender Form*) to supply(*description of the Works*) (hereinafter called “the Contract);

AND WHEREAS it has been stipulated by you in the said Contract that the Contractor shall furnish you with an Institution’s guarantee by an acceptable Institution for the sum specified therein as security for compliance of the Contractor’s performance obligations in accordance with the Contract;

AND WHEREAS we have agreed to give the Contractor a Guarantee;

THEREFORE WE HEREBY AFFIRM that we are Guarantors and responsible to you, on behalf of the Contractor, up to a total of..... (*amount of the guarantee in words and figures*) and we undertake to pay you, upon your first written demand declaring the Contractor to be in default under the Contract and without cavil or argument, any sum or sums within the limits of (*amount of guarantee*) as aforesaid, without you needing to prove or to show grounds or reasons for your demand or the sum specified therein.

This guarantee is valid until theday of.....20....

EITHER

SEALED with the)
COMMON SEAL)
of the said **INSTITUTION**)

)
thisday)
)
of20....)
in the presence of :-)

_____)
)
and in the presence of:-)

INSTITUTION SEAL

_____)
_____)

OR

SIGNED by the **DULY AUTHORISED REPRESENTATIVE(S)/ ATTORNEY(S)** of the **INSTITUTION**

Name(s) and Designation of duly authorised representative(s)/ attorney(s) of the **Institution.**

Signature(s) of the duly authorised person(s)

NOTES TO SUPPLIERS AND INSTITUTIONS

1. *Please note that no material additions, deletions or alterations regarding the contents of this Form shall be made to the Tender Security to be furnished by the Tenderer. If any are made, the Tender Security shall not be accepted and shall be rejected by KPLC. For the avoidance of doubt, such rejection will be treated as non-submission of the Tender Security where such Security is required in the tender.*
2. *It is the responsibility of the Tenderer to sensitize its issuing institution on the need to respond directly and expeditiously to queries from KPLC. The period for response shall not exceed three (3) days from the date of KPLC's query. Should there be no conclusive response by the institution within this period, such Tenderer's Tender Security shall be deemed as invalid and the bid rejected.*
3. ***The issuing institution should address its response or communication regarding the Tender Security to KPLC at the following e-mail address – “guarantees@kplc.co.ke”***
4. *The Tender validity period is one hundred and eighty (180) days as set out in the Invitation to Tender (at Section I of the Tender document) or as otherwise may be extended by KPLC. Therefore the Tender Security must at all times be valid for at least 30 days beyond the tender validity period.*

SECTION XI C - TENDER SECURITY – (LETTERS OF CREDIT)

The Mandatory Conditions to be included in the Letters are in two parts, A and B.

Part A

Form of Documentary credit - “Irrevocable Standby”

Applicable rules - “Must be UCP Latest Version” i.e. UCP 600 (2007 REVISION) ICC Publication No. 600.

Place of expiry - At the counters of the advising bank.

The SBLC should be available – “By Payment”

Drafts should be payable at - “SIGHT”

Documents required -

1. Beneficiary’s signed and dated statement demanding for payment under the letter of credit no..... (*Insert LC No.*) as.....(*Name of applicant*) (hereinafter called the “Tenderer”) indicating that the “Tenderer” has defaulted in the obligations of the Tenderer as stated by the Beneficiary.
2. The Original Letter of Credit and all amendments, if any.

Additional Conditions -

1. All charges levied by any bank that is party to this documentary credit are for the account of the applicant.
2. There should be no conditions requiring compliance with the specific regulations or a particular country’s Law and regulations.

Charges - All bank charges are for the account of the applicant.

*Confirmation instructions – (See notes below)

Part B

The proceeds of these Letters are payable to KPLC -

- a) if the Tenderer withdraws its Tender after the deadline for submitting Tenders but before the expiry of the period during which the Tenders must remain valid.
- b) if the Tenderer fails to enter into a written contract in accordance with the Tender Document
- c) if the successful Tenderer fails to furnish the performance security in accordance with the Tender Document.
- d) if the Tenderer fails to extend the validity of the tender security where KPLC has extended the tender validity period in accordance with the Tender Document.

NOTES TO TENDERERS AND BANKS.

1. *Please note that should the Tender Security (LC) omit any of the above conditions the LC shall not be accepted and shall be rejected by KPLC. For the avoidance of doubt, such rejection will be treated as non-submission of the LC where such LC is required in the Tender.*
2. *It is the responsibility of the Tenderer to sensitize its issuing bank on the need to respond directly and expeditiously to any queries from KPLC. The period for response shall not three (3) days from the date of KPLC's query. Should there be no conclusive response by the Bank within this period, such Tenderer's Tender Security shall be deemed as invalid and the bid rejected.*
3. ***The issuing bank should address its response or communication regarding the bond to KPLC at the following e-mail address – “guarantees@kplc.co.ke”***
4. *The Tender validity period is one hundred and eighty (180) days as set out in the Invitation to Tender (at Section I of the Tender document) or as otherwise may be extended by KPLC. Therefore the Tender Security must at all times be valid for at least 30 days beyond the tender validity period.*
5. *All Guarantees issued by foreign banks must be confirmed by a local bank in Kenya.*

SECTION XII - MANUFACTURER’S/ PRINCIPAL’S AUTHORIZATION FORM

(To Be Submitted On Manufacturer’s/ Principal’s/ Producer’s Letterhead)

To:

The Kenya Power & Lighting Company Limited,
Stima Plaza,
Kolobot Road, Parklands,
P.O Box 30099 – 00100,
Nairobi, Kenya.

WHEREAS WE(*name of the manufacturer/ principal*) who are established and reputable manufacturers/ principal of (*name and description of the services*) having offices or factories at(*full address and physical location of offices or factory(ies)*) do hereby confirm that (*name and address of Contractor*) is authorized by us to transact in the services required against your Tender (*insert reference number and name of the Tender*) in respect of the above services.

WE HEREBY extend our full guarantee and warranty as per the Conditions of Contract for the services offered for provision by the above firm against the Invitation to Tender.

DATED THIS..... DAY OF.....20.....

Signature of duly authorised person for and on behalf of the Manufacturer/ Principal.

Name and Designation of duly authorised person signing on behalf of the Manufacturer/ Principal.

NOTES TO TENDERERS & MANUFACTURERS/ PRINCIPALS/ PRODUCERS

Only a competent person in the service of the Manufacturer/ Principal should sign this letter of authority.

SECTION XIII - DECLARATION FORM

Date _____

To:

The Kenya Power & Lighting Company Limited,
P.O Box 30099 – 00100,
Stima Plaza, Kolobot Road, Parklands,
Nairobi,
KENYA.

Ladies and Gentlemen,

The Tenderer i.e. (full name and complete physical and postal address) _____
_____ declare the following: -

- a) That I/ We have not been debarred from participating in public procurement by anybody, institution or person.
- b) That I/ We have not been involved in and will not be involved in corrupt and fraudulent practices regarding public procurement anywhere.
- c) That I/We or any director of the firm or company is not a person within the meaning of paragraph 3.2 of ITT (Eligible Tenderers) of the Instruction to Tenderers.
- d) That I/ We are not insolvent, in receivership, bankrupt or in the process of being wound up and is not the subject of legal proceedings relating to the foregoing.
- e) That I/We do hereby confirm that all the information given in this tender is accurate, factual and true to the best of our knowledge.
- f) That I/ We are not associated with any other Tenderer participating in this tender.

Yours sincerely,

Name of Tenderer

Signature of duly authorised person signing the Tender

Name and Designation of duly authorised person signing the Tender

Stamp or Seal of Tenderer

SECTION XIV – DRAFT LETTER OF NOTIFICATION OF AWARD

To:

(Name and full address of the Successful Tenderer).....

Dear Sirs/ Madams,

RE: NOTIFICATION OF AWARD OF TENDER NO.

We refer to your Tender dated..... and are pleased to inform you that following evaluation, your Tender has been accepted as follows: -

.....
.....

This notification does not constitute a contract. The formal Contract Agreement, which is enclosed herewith shall be entered into upon expiry of fourteen (14) days from the date hereof pursuant to the provisions of the Public Procurement and Asset Disposal Act, 2015 *(or as may be amended from time to time or replaced)*.

Kindly sign, and seal the Contract Agreement. Further, initial and stamp on all pages of the documents forming the Contract that are forwarded to you with this letter. Thereafter return the signed and sealed Contract together with the documents to us within fourteen (14) days of the date hereof for our further action.

We take this opportunity to remind you to again note and strictly comply with the provisions as regards the Tender Security, Signing of Contract and Performance Security as stated in the Instructions to Tenderers.

We look forward to a cordial and mutually beneficial business relationship.

Yours faithfully,

FOR: THE KENYA POWER & LIGHTING COMPANY LIMITED

GENERAL MANAGER, SUPPLY CHAIN

Enclosures

SECTION XV – DRAFT LETTER OF NOTIFICATION OF REGRET

To: *(Name and full address of the Unsuccessful Tenderer)*.....

Date:

Dear Sirs/ Madams,

RE: NOTIFICATION OF REGRET IN RESPECT OF TENDER NO.

We refer to your Tender dated..... and regret to inform you that following evaluation, your Tender is unsuccessful. It is therefore not accepted. The brief reasons are as follows:-

1.
2.
3. etc...

The successful bidder was _____.

However, this notification does not reduce the validity period of your Tender Security. In this regard, we request you to relook at the provisions regarding the Tender Security, Signing of Contract and Performance Security as stated in the Instructions to Tenderers.

You may collect the tender security from our *Legal Department (Guarantees Section)*, on the 2nd Floor, Stima Plaza, Kolobot Road, Parklands, Nairobi only after expiry of twenty five (25) days from the date hereof on Mondays and Wednesdays ONLY between 9.00 a.m to 12.30 pm and 2.00p.m to 4.00p.m.

It is expected that by that time KPLC and the successful bidder will have entered into a contract pursuant to the Public Procurement and Asset Disposal Act, 2015 *(or as may be amended from time to time or replaced)*. When collecting the Security, you will be required to produce the original or certified copy of this letter.

We thank you for the interest shown in participating in this tender and wish you well in all your future endeavours.

Yours faithfully,

FOR: THE KENYA POWER & LIGHTING COMPANY LIMITED

GENERAL MANAGER, SUPPLY CHAIN

SECTION XVI - CONTRACT AGREEMENT FORM

THIS AGREEMENT made this.....day of.....**20.....** **BETWEEN THE KENYA POWER & LIGHTING COMPANY LIMITED**, a limited liability company duly incorporated under the Companies Act, Chapter 486 of the Laws of Kenya, with its registered office situated at Stima Plaza, Kolobot Road, Parklands, Nairobi in the Republic of Kenya and of Post Office Box Number 30099-00100, Nairobi in the Republic aforesaid (*hereinafter referred to as the “KPLC”*) of the one part,

AND

..... (*Contractor’s full name and principal place of business*) a duly registered entity according to the laws of (*state country*) and of Post Office Box Number/Physical Address (*full address physical and postal of Contractor*) in the Republic aforesaid, (*hereinafter referred to as the “Contractor”*) of the other part;

WHEREAS KPLC invited tenders for certain services, that is to say for Tender No. KP1/9A.2/DT/014/ICT/19-20 for procurement of annual support & maintenance services for fox telecommunication transport system.

AND WHEREAS KPLC has accepted the Tender by the Contractor for the services in the sum of (*hereinafter called “the Contract Price”*).

NOW THIS AGREEMENT WITNESSETH AS FOLLOWS: -

1. In this Agreement words and expressions shall have the same meanings as are respectively assigned to them in the Conditions of Contract and the Tender Document.
2. Unless the context or express provision otherwise requires: -
 - a) reference to “this Agreement” includes its recitals, any schedules and documents mentioned hereunder and any reference to this Agreement or to any other document includes a reference to the other document as varied supplemented and or replaced in any manner from time to time.
 - b) any reference to any Act shall include any statutory extension, amendment, modification, re-amendment or replacement of such Act and any rule, regulation or order made thereunder.

- c) words importing the masculine gender only, include the feminine gender or (as the case may be) the neutral gender.
 - d) words importing the singular number only include the plural number and vice-versa and where there are two or more persons included in the expression the “*Contractor*” the covenants, agreements obligations expressed to be made or performed by the Contractor shall be deemed to be made or performed by such persons jointly and severally.
 - e) where there are two or more persons included in the expression the “*Contractor*” any act default or omission by the Contractor shall be deemed to be an act default or omission by any one or more of such persons.
3. In consideration of the payment to be made by KPLC to the Contractor as hereinbefore mentioned, the Contractor hereby covenants with KPLC to perform and provide the services and remedy any defects thereon in conformity in all respects with the provisions of the Contract.
 4. KPLC hereby covenants to pay the Contractor in consideration of the proper performance and provision of the services and the remedying of defects therein, the Contract Price or such other sum as may become payable under the provisions of the Contract at the times and in the manner prescribed by the Contract.
 5. The following documents shall constitute the Contract between KPLC and the Contractor and each shall be read and construed as an integral part of the Contract: -
 - a) this Contract Agreement
 - b) the Special Conditions of Contract as per the Tender Document
 - c) the General Conditions of Contract as per the Tender Document
 - d) the Price Schedules submitted by the Contractor and agreed upon with KPLC.
 - e) the Details of Service as per KPLC’s Tender Document
 - f) the Schedule of Requirements
 - g) KPLC’s Notification of Award dated.....
 - h) the Tender Form signed by the Contractor
 - i) the Declaration Form signed by the Contractor/ successful Tenderer
 - j) the Warranty
 - h) project implementation schedule
 6. In the event of any ambiguity or conflict between the contract documents listed above, the order of precedence shall be the order in which the contract documents are listed in 5 above except where otherwise mutually agreed in writing.

7. The Commencement Date shall be the working day immediately following the fulfillment of all the following: -
 - a) Execution of this Contract Agreement by KPLC and the Contractor.
 - b) Issuance of the Performance Bond by the Contractor and confirmation of its authenticity by KPLC.
 - c) Issuance of the Official Order by KPLC to the Contractor.
 - d) Where applicable, Opening of the Letter of Credit by KPLC.

8. The period of contract validity shall begin from the Commencement date and end on either -
 - a) sixty (60) days after the last date of the agreed performance schedule, or,
 - b) where a Letter of Credit is adopted as a method of payment, sixty (60) days after the expiry date of the Letter of Credit or the expiry date of the last of any such opened Letter of Credit whichever is later.

Provided that the expiry period of the Warranty shall be as prescribed and further provided that the Warranty shall survive the expiry of the contract.

9. It shall be the responsibility of the Contractor to ensure that its Performance Security is valid at all times during the period of contract validity and further is in the full amount as contracted.

10. Any amendment, change, addition, deletion or variation howsoever to this Contract shall only be valid and effective where expressed in writing and signed by both parties.

11. No failure or delay to exercise any power, right or remedy by KPLC shall operate as a waiver of that right, power or remedy and no single or partial exercise of any other right, power or remedy.

12. Notwithstanding proper completion of performance or parts thereof, all the provisions of this Contract shall continue in full force and effect to the extent that

any of them remain to be implemented or performed unless otherwise expressly agreed upon by both parties.

13. Any notice required to be given in writing to any Party herein shall be deemed to have been sufficiently served, if where delivered personally, one day after such delivery; notices by electronic mail shall be deemed to be served one day after the date of such transmission and delivery respectively, notices sent by post shall be

deemed served seven (7) days after posting by registered post (*and proof of posting shall be proof of service*), notices sent by courier shall be

deemed served two (2) days after such receipt by the courier service for Local Suppliers and five (5) days for Foreign Suppliers.

14. For the purposes of Notices, the address of KPLC shall be Company Secretary, The Kenya Power & Lighting Company Limited, 7th Floor, Stima Plaza, Kolobot Road, Post Office Box Number 30099–00100, Nairobi, Kenya. The address for the Contractor shall be the Contractor’s address as stated by it in the Confidential Business Questionnaire provided in the Tender Document.

IN WITNESS whereof the parties hereto have caused this Agreement to be executed in accordance with the laws of Kenya the day and year first above written.

SIGNED for and on behalf
of **KPLC**

MANAGING DIRECTOR & CEO

and in the presence of:-

COMPANY SECRETARY

SEALED with the **COMMON SEAL**
of the **CONTRACTOR**
in the presence of:-

DIRECTOR

Affix Contractor’s Seal here

DIRECTOR’S FULL NAMES

and in the presence of:-

DIRECTOR/ COMPANY SECRETARY

DIRECTOR/ COMPANY SECRETARY'S FULL NAMES

DRAWN BY: -

Imelda Bore,

Advocate,

C/o The Kenya Power & Lighting Company Limited,

7th Floor, Stima Plaza,

Kolobot Road, Parklands,

Post Office Box Number 30099-00100,

NAIROBI, KENYA,

Telephones: + 254-20-3201000/ 731

SECTION XVII A - PERFORMANCE SECURITY FORM (BANK GUARANTEE)

(To Be Submitted On Bank’s Letterhead)

Date:

To:

The Kenya Power & Lighting Company Limited,
Stima Plaza,
Kolobot Road, Parklands,
P.O Box 30099 – 00100,
Nairobi, Kenya.

WHEREAS.....(hereinafter called “the Supplier”) has undertaken, in pursuance of your Tender Number.....(*reference number of the Tender*) and its Tender dated(*insert Supplier’s date of Tender taken from the Tender Form*) to supply(*description of the goods*) (hereinafter called “the Contract);

AND WHEREAS it has been stipulated by you in the said Contract that the Supplier shall furnish you with a bank guarantee by an acceptable bank for the sum specified therein as security for compliance of the Supplier’s performance obligations in accordance with the Contract;

AND WHEREAS we have agreed to give the Supplier a guarantee;

THEREFORE WE HEREBY AFFIRM that we are Guarantors and responsible to you, on behalf of the Supplier, up to a total sum of..... (*amount of the guarantee in words and figures*) and we undertake to pay you, upon your first written demand declaring the Supplier to be in default under the Contract and without cavil or argument, any sum or sums within the limits of (*amount of guarantee*) as aforesaid, without you needing to prove or to show grounds or reasons for your demand or the sum specified therein.

This guarantee is valid until theday of.....20....

EITHER

SEALED with the)
COMMON SEAL)
of the said **BANK**)
)

thisday) _____
) BANK SEAL
 of20....)
 in the presence of :-)
)
 _____)
)
 and in the presence of:-)
)
 _____)

OR

SIGNED by the **DULY AUTHORISED**
REPRESENTATIVE(S)/ ATTORNEY(S) of
 the **BANK**

 Name(s) and Designation of duly authorised representative(s)/ attorney(s) of the Bank

 Signature(s) of the duly authorised person(s)

NOTES TO SUPPLIERS AND BANKS

1. *Please note that no material additions, deletions or alterations regarding the contents of this Form shall be made to the Performance Security Bond (the Bond) to be furnished by the successful Tenderer/ Supplier. If any are made, the Bond may not be accepted and shall be rejected by KPLC. For the avoidance of doubt, such rejection will be treated as non-submission of the Bond where such Bond is required in the tender and Contract.*

2. *KPLC shall seek authentication of the Performance Security from the issuing bank. It is the responsibility of the Supplier to sensitize its issuing bank on the need to respond directly and expeditiously to queries from KPLC. The period for response shall not exceed five (5) days from the date of KPLC’s query. Should there be no conclusive response by the Bank within this period, such Supplier’s Performance Security may be deemed as invalid and the Contract nullified.*

3. *The issuing Bank should address its response or communication regarding the bond to KPLC at the following e-mail address – “guarantees@kplc.co.ke”*

SECTION XVII B - PERFORMANCE SECURITY (LC)

Mandatory Conditions that should appear on the Performance Security (LC).

Form of Documentary credit - “Irrevocable Standby”

Applicable rules - “Must be UCP Latest Version” i.e. UCP 600 (2007 REVISION) ICC Publication No. 600.

Place of expiry - At the counters of the advising bank.

The SBLC should be available – “By Payment”

Drafts should be payable at - “SIGHT”

Documents required -

1. Beneficiary’s signed and dated statement demanding for payment under the letter of credit no..... *(Insert LC No.)* as.....*(Name of Applicant)* (hereinafter called the “Supplier”) indicating that the “Supplier” has defaulted in the performance and adherence to and performance of the contract between the Beneficiary and the Supplier.
2. The Original Letter of Credit and all amendments, if any.

Additional Conditions -

1. All charges levied by any bank that is party to this documentary credit are for the account of the Applicant.
2. (Include) that there should be no conditions requiring compliance with the specific regulations or a particular country’s laws and regulations.

Charges - All bank charges are for the account of the Applicant.

Confirmation instructions – (See notes below)

NOTES TO SUPPLIERS AND BANKS

1. *Please note that should the Performance Security (LC) omit any of the above conditions the LC shall not be accepted and shall be rejected by KPLC. For the avoidance of doubt, such rejection will be treated as non-submission of the LC where such LC is required in the tender and Contract.*
2. *KPLC may seek authentication of the Performance Security (LC) from the issuing bank. It is the responsibility of the Supplier to sensitize its issuing bank on the need to respond directly and expeditiously to queries from KPLC. The period for*

response shall not exceed three (3) days from the date of KPLC's query. Should there be no conclusive response by the Bank within this period, such Supplier's Performance Security (LC) may be deemed as invalid and the Contract nullified.

- 3. *The issuing bank should address its response or communication regarding the bond to KPLC at the following e-mail address – “guarantees@kplc.co.ke”***
4. *All Guarantees issued by foreign banks must be confirmed by a local bank in Kenya.*

SECTION XVIII – SUBCONTRACTORS

(INFORMATION TO BE PROVIDED BY THE TENDERER)

As per the requirements of Clause 7.23 of General Conditions of Contract, following is a list of subcontractors and the portions of the Work to be subcontracted:

No.	Subcontractor	Address	Brief Description of the Works to be Subcontracted	% works subcontracted

SECTION XIX - PREVIOUS EXPERIENCE WITH SIMILAR WORK

(INFORMATION TO BE PROVIDED BY THE TENDERER)

As required by Section 3.13.3(d) of the Instructions To Tenderers, following is a list of work that the Tenderer has previously performed which is similar to that described in the Request for Proposal:

No.	Description	Customer Name & Contacts	Date of Supply

SECTION XX - SUPPLIER EVALUATION FORM

(This form is for information only and not to be filled in by any bidder. It is for official use by KPLC to evaluate performance of Suppliers during the contract period)

Name of Firm.....Date.....

Category of Product/Service (e.g. Conductors

Period of evaluation.....

1. COST OF SERVICE/PRODUCT	Rating guidelines	Supplier Score	Procurement Score	User Score	Comments	Totals
	Did the vendor assist in or advice on ways of reducing the costs? YES: 4 PARTIAL LY:2 NO: 0					10
	How closely did your final costs correspond to your expectation at the beginning of the project/tender? YES: 2 PARTIAL LY:1 NO: 0					10.00%
	Did the company stick to the agreed transaction/contract rates? YES: 4 PARTIAL LY:2 NO: 0					
						Totals
2.ON TIME DELIVERY OF PRODUCT OR SERVICE						
	Did the vendor perform work in compliance with contract terms and agreements? YES: 6 PARTIAL LY:3 NO: 0					10
	Was the vendor prompt and effective in correction of situations and conditions? YES: 2 PARTIAL LY:1 NO: 0					10.00%
	Are you able to track service level agreements and determine duration of incidents from the vendor? YES: 2 PARTIAL LY:1 NO: 0					
3. FLEXIBILITY TO RESPOND TO UNEXPECTED DEMAND OF SERVICE						
	Rating guidelines Was the vendor willing to change their product/service on special needs? YES: 6 PARTIAL LY:3 NO: 0					6
						6.00%
4. QUALITY						
	Rating guidelines When performing their duties, was there - rework or returns caused by non-conformance to quality? NO:6 PARTIAL LY:3 YES: 0					14
	Was the quality of service delivered equal to KPLC minimum requirements? YES: 8 PARTIAL LY:4 NO:0					14.00%
5.RESPONSIVENESS						
	Rating guidelines Was the vendor well responsive to information requests, issues, or problems that arose in the course of service? YES: 2 PARTIAL LY:1 NO: 0					14
	Was the vendor open to feedback on low quality of service levels and willing to act on this? YES: 6 PARTIAL LY:3 NO: 0					14.00%
	Is it easy to reach staff members of suppliers in case of a request or query? (are communication channels clear?) YES: 6 PARTIAL LY:3 NO: 0					
6. CUSTOMER SUPPORT						
	Rating guidelines Did the vendor offer effective customer support? YES: 10 PARTIAL LY:4 NO: 0					18
	In case of reported problems/issues, were there follow ups by the vendor to ensure the problem is fully resolved during support? YES: 8 PARTIAL LY:4 NO: 0					18.00%

7. COMMUNICATION SKILLS	Rating guidelines								Totals
	Are you satisfied with the attitude, courtesy, and professionalism of this vendor's staff? Written or spoken?	YES: 2	PARTIAL LY:1	NO: 0					6
	Are the vendor's staff well equipped and skilled in handling requests / issues? Are you rotated too much among staff on an issue?	YES: 4	PARTIAL LY:2	NO: 0					6.00%
8. DOCUMENTATION AND ACCOUNTING	Rating guidelines								Totals
	Are you satisfied with how the Vendor presents documentation (invoices & licenses etc) when required to do so, to necessitate finalization of contract renewals and payments?	YES: 6	PARTIAL LY:3	NO: 0					10
	Was problem documentation (incident reports) presented promptly by the vendor and was it complete?	YES: 4	PARTIAL LY:2	NO: 0					10.00%
9. VALUE ADD	Rating guidelines								Totals
	Did the vendor go over and above in optimizing service delivery process for effective services delivery?	YES: 6	PARTIAL LY:3	NO: 0					12
	Did the vendor go over and above and offer training or knowledge to assist with better systems support?	YES: 6	PARTIAL LY:3	NO: 0					12.00%
									Totals Score:
Totals									100.0
Maximum Score							100.0		100.00%
VENDOR'S TOTAL SCORE									
VENDOR'S PERCENTAGE SCORE									
ISSUES FOR FOLLOW UP -									
Evaluation Done by: Name Department Date									
Checked/Validated by									

Score in Percentage %

PERFORMANCE LEVEL DEFINATION;

- ≥75% - KP1 GREEN
- 50% - KP2 AMBER
- 25% - KP3 YELLOW
- ≤ 25% - KP4 RED

RATING: 75% - V Good, 50% - Good, 25% - Fair, Below 25% - Poor

RECOMMENDATION

		Status	Tick as appropriate
1	Grant supplier preferred status	KP1	
2	Work with supplier or develop and	KP2 & KP3	

	improve supplier		
3	Abandon / switch suppliers	KP4	

Name:.....Sign:.....Date:.....

Name:.....Sign:.....Date:.....

Name:.....Sign:.....Date:.....

SECTION XXI - PRE-BID MEETING ATTENDANCE FORM

CONFIRMATION OF PRE-BID MEETING ATTENDANCE

Name of Tenderer.....

Date of Visit.....

Name, position and signature of the Tenderer's staff visiting the site.

Name:.....

Position.....

Qualification

Signature..... Tenderer's Official Stamp.....

Site Visit conducted by Kenya Power Authorised Officer's

Name

Signature.....

SECTION XXII - THE DETAILS OF SERVICES

The Details of Services describe the basic requirements for services. In addition to the information and documentation in the Tender Document regarding the technical aspects of this tender, all Tenderers shall comply with the following -

PART A - GENERAL REQUIREMENTS

1. Technical documentation shall be in English language. The specific services on offer shall be marked clearly for the services they intend to provide.
2. Deviations from the basic requirements, if any, shall be explained in detail in writing with the offer, with supporting data including calculation sheets, detailed drawings and certified test reports. KPLC reserves the right to reject the services if such deviations shall be found critical to the use and operation of the services.
3. The Contractor shall submit a Commentary on the Details of Service as well as Commentary of Compliance to the Details of Service. In submitting the Commentaries the Contractors and or Manufacturers/ Principals should provide cross-references to the documents submitted.
4. The Commentaries shall be in table form, and shall cover in detail, all clauses of the Detail(s).
5. Detailed contact information including title, e-mail, facsimile, telephone or any other form of acceptable communication of the certification or recognition and standards body used shall be provided.
6. Where Certificates and their Reports and are translated into English, all pages of the translations must be signed and stamped by the certifying authority.
7. The Manufacturer's/ Principal's Declaration of Conformity to reference standards and copies of quality management certifications including valid and current ISO certifications shall be submitted for evaluation.
8. In all cases where the level of galvanizing and painting is not specifically stated in the Details, the general requirement shall be for a uniform coating of thickness not less than 80 microns.
9. Contractors are required to provide information on proper representative(s) and or workshop for back-up service and or repair and maintenance including their names, telephone, facsimile, e-mail, physical and postal addresses, along with their offers.

PART B – DETAILED TECHNICAL SPECIFICATIONS (DTS)

1. SCOPE OF WORKS

KPLC is intending to procure Supply, Delivery, Installation and Testing of 2No. x 250KW UPS for its Disaster Recovery Centre in Electricity House Nairobi.

The Contractor shall carry out all the necessary works for successful installation of the 2No. x 250KW UPSs as described and set out in previous sections on the Technical Specification. The Contractor is to integrate with LV Board.

2. UPS TERMS

	Term	Definition
a.	UPS on-line double conversion	An on-line UPS uses a "double conversion" method of accepting AC input, rectifying to DC for passing through the rechargeable battery (or battery strings), then inverting back for powering the protected equipment. A line-interactive UPS maintains the inverter in line and redirects the battery's DC current path from the normal charging mode to supplying current when power is lost.
b.	UPS Module	It has all the hardware and software needed for autonomous operation: rectifier, inverter, DC booster, static bypass switch, back feed protection, control logic, monitoring interfaces, control panel.
c.	DPA architecture	The Decentralized Parallel Architecture (DPA) is implemented in the modular UPS by keeping essential functions independent and decentralized for: <ul style="list-style-type: none"> - Rectifier, Inverter, Static bypass switch - UPS control logic - Battery The architecture allows each UPS Module to operate autonomous offering high system reliability and continuous operation in the unlikely event of one UPS module failing.
d.	UPS unit	It consists of UPS module(s), rectifier and bypass protections, battery circuit breaker protection, UPS output switch, control and monitoring interfaces, input/output terminals housed in a metal enclosure.
e.	Online swapability	The UPS module shall be inserted or removed from the UPS system without transferring the load to the unprotected AC mains supply (bypass)
f.	UPS Maintenance bypass switch (MBS)	UPS MBS is designed to isolate the UPS unit, or part thereof, from the load and to maintain continuity of load power via an alternative path during maintenance activities
g.	Standalone UPS unit (S)	UPS consisting of a UPS unit equipped with system graphical

		display and MBS
h.	Parallel UPS Unit (P)	UPS consisting of up to six (6) UPS units equipped with system graphical display.
i.	Circuit breaker with thermomagnetic trip	an automatically operated electrical switch designed to protect an electrical circuit from damage caused by overcurrent or overload or short circuit.
j.	UPS Output switch	controllable switch used in accordance with applicable requirements for load power continuity to interconnect or isolate power ports of UPS unit
k.	Load sharing	simultaneous supply of power to a load from two or more UPS modules/UPS units
l.	Double conversion mode	Operating mode, where continuity of load power is maintained by the UPS inverter, with energy supplied from the d.c. link in normal mode of operation or from the energy storage system in stored energy mode of operation The UPS attains under the following conditions: a) a.c. input supply is within required tolerances and supplies the UPS; b) the energy storage system remains charged or is under recharge; c) the load is within the specified rating of the UPS; d) the bypass is available and within specified tolerances (if applicable)
m.	Bypass mode operation	mode of operation that the UPS attains when the load is supplied via the bypass main supply only
n.	Battery mode operation	stable mode of operation that the UPS attains under the following conditions: a) a.c. input power is disconnected or is out of required tolerance; b) all power is derived from the energy storage system; c) the load is feed by the UPS module inverter d) the load is within the specified rating of the UPS;
o.	UPS Module stand-by mode	The UPS module goes into stand-by mode by turning off the inverter. The rectifier, battery charger and control logic are active. The stand-by mode is activated under following conditions: a) input supply is within required tolerances and supplies the UPS; b) the energy storage system remains charged or is under recharge; c) the load is not higher than the power provided by the active UPS modules
p.	Float voltage	It is the voltage at which a battery is maintained after being fully charged to maintain that capacity by compensating for self-discharge of the battery.

q.	Power factor	ratio of the absolute value of the active power P (Watt) to the apparent power S (VA)
r.	Rated output	The apparent power S (VA), that can be continuously delivered by the UPS unit over the range of conditions of service and electrical loading without exceeding component ratings or any of the required output tolerances.
s.	Mean Time Between Failure (MTBF)	Mean Time Between Failures (MTBF) is a measure of the average time a device will function before failing. MTBF ratings are measured in hours and indicate the reliability of hardware devices
t.	Mean Time To Repair (MTTR)	Mean Time To Repair (MTTR) measures the total time in hours from when a device fails until when it is restored to full operation, divided by number of faults. It generally does not include lead time for parts not readily available or other administrative or logistic downtimes
u.	Autonomy time of the UPS	The time during which the UPS is able to deliver its rated output within the specified a.c. voltage limits when the battery is the sole source of energy.
v.	End of discharge voltage	The voltage at which the battery discharge is terminated and at which the UPS will stop the battery mode and generate the relatives alarm and events.
w.	Cold start	The cold start (also known as black start or battery start) function allows starting a UPS without the input mains present during the status UPS total off. The startup will be made directly from the battery power and will remain running for a limited time.
x.	IP code	International Protection Marking (or also called Ingress Protection Marking) classifies and rates the degree of protection provided against intrusion (body parts such as hands and fingers), dust, accidental contact, and water by the UPS enclosure. The digits (characteristic numerals) represents: <ul style="list-style-type: none"> • first digit, single numeral 0–6, Solid particle protection • second digit, single numeral 0–9, Liquid ingress protection

3. UPS MODES OF OPERATION

The UPS shall be designed to operate as a true on-line, double conversion Voltage and Frequency Independent (VFI) system in the following modes:

- A. Normal - The critical AC load is continuously supplied by the UPS inverter. The input converter derives power from the utility AC source and supplies DC power to the inverter. The battery charger shall maintain a float-charge on the battery.
- B. Enhanced normal-mode (double conversion) – The UPS system adapts the power capacity to the partial AC load by putting the residual UPS module in stand-by mode. The UPS system autonomously decides which UPS module goes into stand-by mode. The system shall rotate/swap the UPS modules between the

- normal mode and the stand-by mode to extend the operating life and equalize aging.
- C. Battery - Upon failure of utility AC power the critical AC load is supplied by the inverter, which obtains power from the battery. There shall be no interruption in power to the critical load upon failure or restoration of the utility AC source.
 - D. Recharge - Upon restoration of utility AC power, after a utility AC power outage, the input converter shall automatically restart and resume supplying power to the inverter. Also the battery charger shall recharge the battery.
 - E. In addition to the input conversion soft start of each UPS module, when a mains recovery occurs, all single input converters shall switch on in a sequential way with a delay of 2-5 seconds from each to the other module within the system configuration.
 - F. Automatic Restart - Upon restoration of utility AC power, after a utility AC power outage and complete battery discharge, the UPS shall automatically restart and resume supplying power to the critical load on inverter.
 - G. Static-bypass - The static-bypass shall provide an alternate path for power to the critical load that shall be capable of operating in the following manner:
 - a. Automatic - In the event of an internal failure or should the inverter overload capacity be exceeded, all UPS modules shall perform an automatic transfer of the critical AC load from the inverter to the bypass source.
 - b. Eco-Mode – The UPS module(s) shall be able to operate in Eco-Mode when the power quality parameters of the by-pass source are within the permissible tolerances. The UPS system shall automatically transfer the load to normal mode if the by-pass source goes out of permissible tolerances. Transfer in both directions shall take place very rapidly (< 5ms) and shall not affect the supplied load.
 - c. Manual - Manual activation of the bypass shall cause an immediate transfer of the critical AC load from the inverter to the bypass source on all modules of the system.

4. ENERGY STORAGE SYSTEM (ESS)

- A. The ESS could consist of lithium-ion batteries or valve regulated, lead acid or nickel cadmium batteries. Flame retardant batteries shall be provided, which renders the UPS suitable for installation inside a computer room.
- B. The batteries shall be housed in cabinet/s comprising a floor-standing steel enclosure with dimensions and paint finish to match the UPS system cabinet/s to form a continuous suite when standing immediately adjacent to the UPS system cabinet/s. The battery cabinet/s shall have full width opening doors to permit ease of access for the purposes of maintenance and/or repair of the batteries.

- C. The ESS shall be sized to support a connected load of 125kW for a minimum of 60 minutes at an ambient temperature of 25 °C
- D. The UPS shall interface with the energy storage cabinet by 2 wired connections (+) and (-)
- E. The battery enclosure shall be equipped with internal safety protection devices to protect from overcharge and short circuit.
- F. For ESS made by lithium-ion batteries, cells must be assembled within battery modules containing maximum 8 cells each. Each battery module shall have its dedicated control board to measure voltage and current on each single cell. It shall also measure temperature values on at least two different positions located inside of each battery module.
- G. Each battery string shall be assembled into a dedicated battery cabinet together with battery management system fuse and molded case circuit breaker also in case of multiple battery strings connected in parallel.
 Each battery string shall provide a balancing system able to manage single cell voltage imbalance inside of each battery module.
 Each battery string shall be managed by a battery management system which shall gather all data from battery modules (voltage current and temperature) and calculate state of charge and state of health of the system.
 Each battery string shall be equipped with one fuse and one molded case circuit breaker (both shall be present). The MCCB shall be managed by the battery management system and it shall be able to disconnect the battery string in case of major events like cell over temperature, overvoltage and overcurrent. Battery management system shall support Modbus communication and dry contacts and it shall be provided with a monitoring software compatible with windows laptops usable from final operators.
 In case of multiple strings in parallel the system shall be able to provide only one point of connection for data communication.
- H. The UPS battery charging circuit shall comprise of a separate battery charger and not depend on a charge voltage being derived from the UPS input rectifier.
 Consequently the battery charging voltage shall have r.m.s. ripple content of <2%.
- I. The battery system shall consist either:
 - 1) a separate battery system for each individual UPS module. In this case each separate battery system may consist of one protected string or multiple protected strings of multiple cells.
or
 - 2) a common battery feeding all the UPS units. In this case the battery system shall consist of a minimum of two parallel strings of multiple cells. Each individual string shall have its own dedicated means of electrical circuit protection.
- J. A fully discharged battery system shall be capable of being recharged to 80% of the UPS output capacity within a maximum period of 10 times the normal total discharge time period.
- K. The UPS DC bus voltage shall be variable whereby the number of battery blocks (12V blocks) can be adjusted between 40 to 50 to enable the battery system to be optimized for size and cost.

- L. The UPS shall initiate an automatic battery testing sequence periodically (once a month), at a programmed day and time of day, selectable by the end user. The user will be able to activate and deactivate the automatic battery test. Should a failure of the battery occur, the UPS will immediately return to normal mode and fault signals (visual, audible, and remote via serial) shall be communicated. No audible or remote (via serial/contact closures) indication of the battery test shall be communicated during the duration of the automatic battery test.
The automatic battery test shall be able to operate only if no alarms conditions affect the UPS and if the battery is at least 90% of its full capacity.

Type F

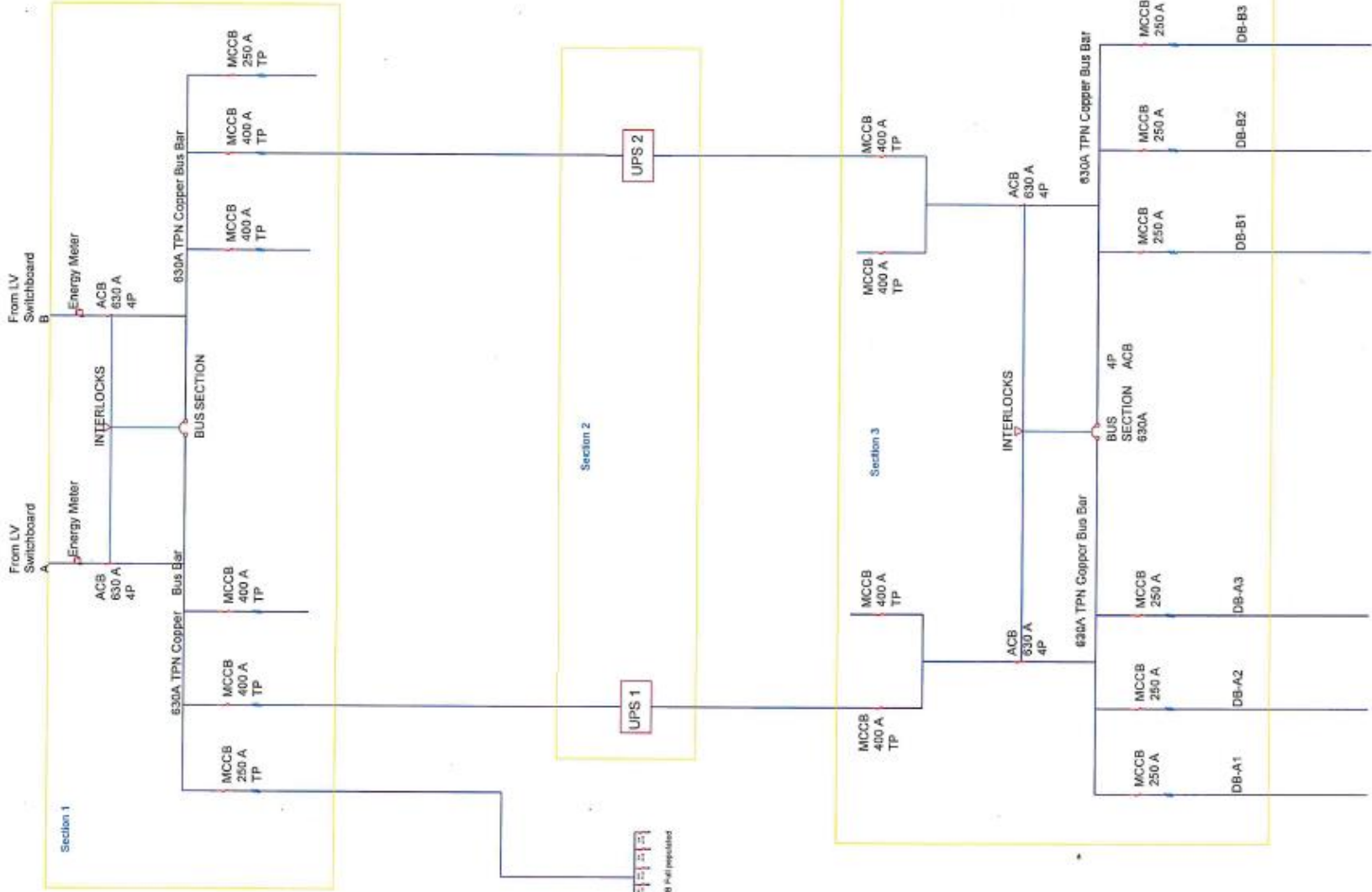

4

 6 Way CB with 4P interlocking

NO	GENERAL NOTES
1	All dimensions in the drawing are in mm.
2	Do not scale from this drawing. The typical dimension ONLY.
3	All Drawings must be read in conjunction with submittal and coordinated P&ID layout.
4	position of cables to be installed and approved prior to installation of lines.
5	The position of various electrical lines as shown on the drawings are provisional. Final positions to be confirmed in the detailed working drawings.
6	The contractor shall check all dimensions and ensure the switches are installed on the back side.

NO	REVISION NOTES



Project: NEW LV SWITCHBOARD FOR ELECTRICITY HOUSE NAIROBI

Client: KENYA POWER

Drawing Title: 100 LV SWITCHBOARD ONE LINE DIAGRAM

Date	Job No.
Drawing No: 07	Revision No.
Date: JAN 2017	Designed: EGM
	Drawn: EGM
	Checked: L.S.I.

Author: